



**INSTRUCTION MANUAL FOR REFLECTION-TYPE LEVEL INDICATORS –Series R**

**1. INSTRUMENT DESCRIPTION**

Reflection-type level indicators display the fluid level through a transparent surface that is part of column connected to the vessel via interception members.

The robust construction and good visibility, **without** dedicated illuminators enable use in heady-duty applications with pressure values up to a rating of PN250 and temperatures up to 300°C.

In order to ensure a proper reading, its use is **not recommended** with fluids that tend to form deposits or scaling.

**2. MODEL IDENTIFICATION**

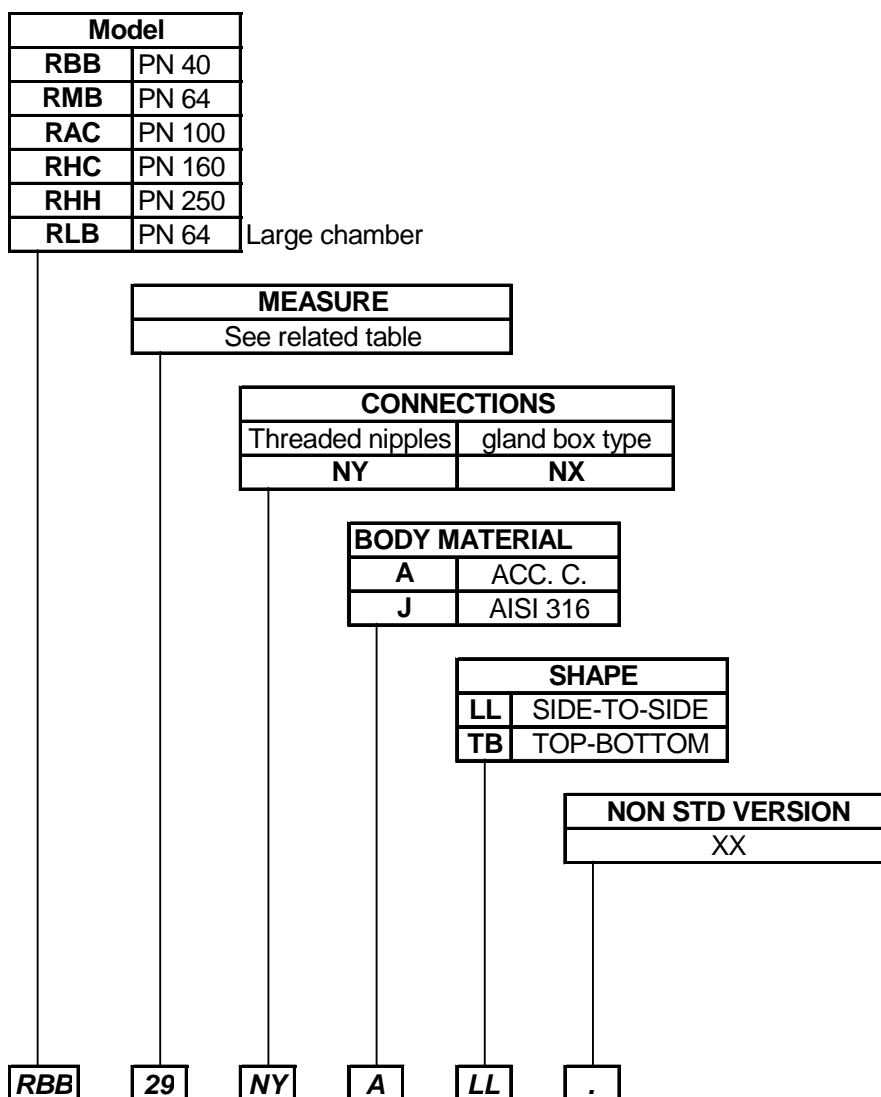

**Accessories:** the instrument can be equipped with various accessories, such as:  
 -reading extension with cryogenic fluids (antifrost);  
 -standard graduation, in centimetres (other engineering units upon request).

**3. OPERATING PRINCIPLES**

The measuring portion includes one or more prismatic crystal members (generally BOROSILICATE) which entail the reflection or non-reflection of environmental light, depending on whether the inner surface is in contact with the fluid or with the gas and/or vapour.

Either the crystal portion that is in contact with the fluid becomes dark or that in contact with the gas remains light in colour.

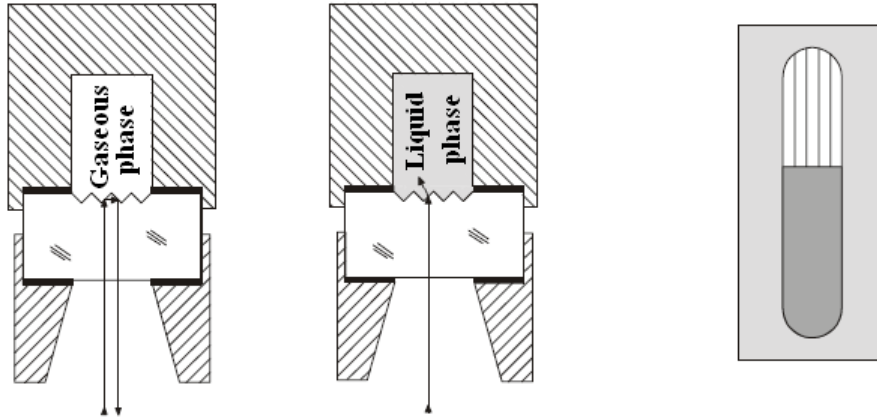

**SAFETY BALL FUNCTION**

The safety ball is used to prevent the fluid to flow out of the vessel in cases when a crystal breaks.

In model NY, the ball (1) automatically **closes** the passage of the flow that is created when the crystal breaks. Once instrument integrity is restored, at the starting stage the knob (2) needs to be pressed so that the bar (3) moves the ball (1) and allows the level gauge body to be correctly filled in. It is always advisable to adopt at least one safety ball, to be located in the lower portion of the device. It is advisable to use two balls, one above and one below, when the vessel level exceeds that of the level gauge (e.g. in the event of several level gauges located in a row).

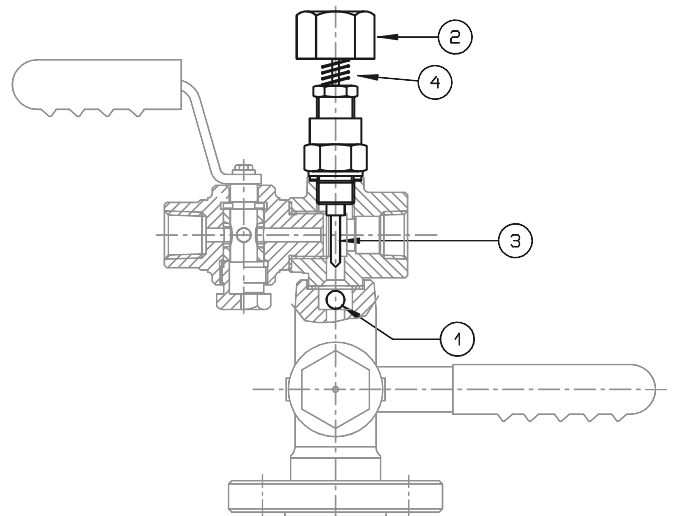

In model YY, the same considerations as those given above apply, except that the ball (2) is moved by the stem at the closing stage. Hence, in order to reset, a closing-opening move is needed.

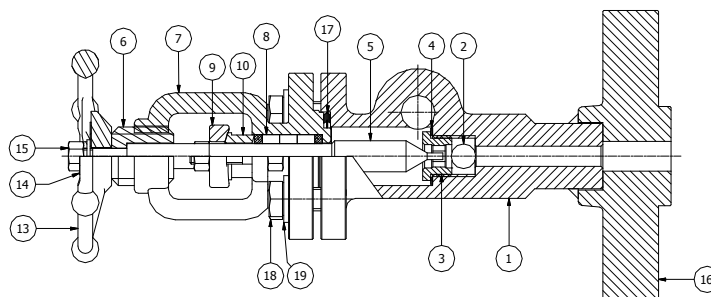



## 4. INSTALLATION

The (standard) instrument is supplied equipped with on/off valves, a drain valve and a safety ball located in the device lower portion. (Standard) connections are **side-to-side** with facing crystal glass. The instrument shall only be installed and used by qualified staff. Before installing it, check vessel and instrument connections for compatibility. It is strictly forbidden to load the device with external loads and it is the user's obligation to protect it from all stress; never use it as a support point. To avoid galvanic corrosion effects, the use of materials with a different electrochemical potential is forbidden. The user shall adopt all technical measures required to preserve the unit from such an event. The system shall be equipped with the prescribed safety valve, to remedy overpressure beyond the maximum expected values. In the event of air or steam bubble formations, please apply relief valves on the upper connections. For installation on vessels exposed to strong vibration, please contact our customer service. The system connection process shall be accurate so that all items (flanges, gaskets, stud bolts) perfectly match to avoid sealing problems and create useless mechanical stress over the system and/or the instrument.

**Warning:** if the fluid in use may turn into ice (e.g. water), the instrument could suffer damages. Therefore, we suggest using a heating tracer.

## 5. FIRST START-UP

Remove all plugs or other protection devices from the connections before starting fitting the instrument onto the system. Ensure that any on/off, drain and relief valves are closed. Connect the device to the system. For very hot fluids, to avoid excessive thermal stress on the crystals, you need to adapt the body temperature to the process temperature, before opening on/off valves. Slowly open the upper on/off valve, to balance pressure values between the instrument and the vessel. Then slowly open the lower on/off valve to let the fluid into the instrument without actuating the safety ball. As soon as pressure inside the instrument has stabilized, the valves can open wide. The instrument has been previously tested and it has been ascertained that it does not have any fluid leaking out of the junctions. In cases when leaks show up owing to the settlement of junctions, the latter shall be clamped as indicated in paragraph 7 (Maintenance). During the first 24 hours of operation, periodically inspect junctions for integrity.

**Warning:**

- Valves are **closed** when the knob is aligned with the connection.
- The drain valve shall only be opened when the instrument is blocked and pressure has been released; at the beginning, the vent shall be opened by a few degrees, so as to slowly release the instrument internal pressure, then action shall be taken on the drain valve to let out all the fluid that is in the level gauge.

## 6. CALIBRATION

The instrument does not require any calibration to be performed (not applicable).

## 7. MAINTENANCE

Maintenance shall **only** be performed by qualified personnel, being perfectly aware of operation and having sound and proven experience with this kind of work. A cyclical inspection is recommended (once every six months approximately) to guarantee the perfect working order of the instrument. More in detail, check crystals for integrity, since some fluids may deeply corrode the glass. Inspect and clean the glass and on/off valves. Moreover, check the bolts for proper tightening. The numerical series shows the bolt tightening sequence. The torque value is indicated in the table below, as a function of the various models. **Note:** all maintenance activities shall **always** be performed with the interceptor instrument emptied of the fluid that is inside, and once it has come back to room temperature

### 7.1. WARNINGS

- **never** use the instrument at a temperature or a pressure that exceeds the values specified on the rating plate;
- **never** perform settings or replace parts without having read the instructions beforehand; in case of doubts, please contact our customer service department;
- **never** lubricate any part of the instrument;
- If the instrument is used with very high temperatures, take all precautionary measures required to guarantee personal protection to the personnel on duty during the various maintenance stages.

## LEVEL BODY DETAIL VIEW

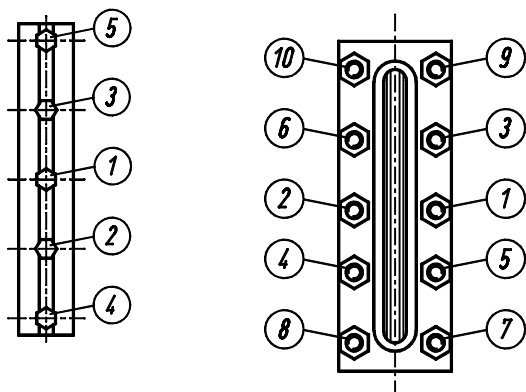

Bolt torque table		
Model	Size	Tightening
RBB	11 - 79	30 Nm
RMB	11 - 79	32 Nm
RAC	11 - 79	35 Nm
RHC	11 - 79	40 Nm
RHH	11 - 79	45 Nm
RLB	12 - 69	30 Nm

## NY VALVE ASSEMBLY DETAIL VIEW

In cases when leaks show up, owing to the settlement of junctions in positions 1 to 5, operate a further tightening until the leak is undone

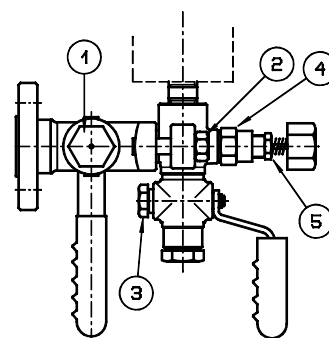

## YY VALVE ASSEMBLY DETAIL VIEW

In cases when leaks show up, owing to the settlement of junctions in position 12, operate a further tightening until the leak is undone.

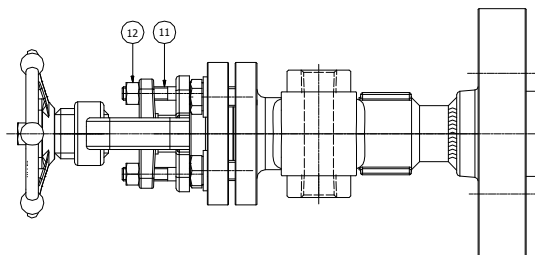

## 7.2. LEVEL BODY MAINTENANCE

### CLEANING OF LEVEL BODY

- Close on/off valve
- Slowly open the vent, until environmental pressure is balanced in the indicator
- Drain the fluid into a suitable vessel
- Open the drain or the drain valve so that the fluid can flow out
- Use a flushing fluid that does not interfere with the process fluid, or does not cause problems to the glass. Clean the indicator inside, if necessary, use a brush.
- Put the indicator into service in accordance with paragraph 5 (First Start-Up)

### VALVE CLEANING

On/Off valves of the glass level indicator cannot be cleaned on site. The cleaning shall only be performed in a laboratory.

**CRYSTAL GLASS REPLACEMENT**

- Note:**
- Crystal glass replacement shall only be made by experienced staff
  - Crystal glass replacement always goes along with gasket replacement
  - Models RBB and RMB are equipped with type “A” crystal glass, 30 mm in width, models RAC, RHC, RHH and RLB are equipped with type “B”, 34 mm in width.
  - Take all the steps set forth in paragraph 7.2 (Level gauge body cleaning)
  - Unscrew the cover nuts (see drawing Level gauge body)
  - Remove the cover
  - Remove all defective glass and replace all leaking gaskets
  - Clean the gasket area (do not use sharp tools)
  - Insert the new gasket in the dedicated area
  - Insert the gasket with the glass inside the cover
  - Insert the reflection glass into the special groove (ensure that the prismatic portion of the crystal is turned inwards)
  - Fit the cover back in place
  - Tighten the bolts as described in paragraph 7
  - Check all tightening again during the first 24 working hours.

**VALVE CASE REPLACEMENT**

See paragraph 9 (suggested spare parts) for number references.

- The replacement of the case shall be performed with the device being disconnected from the system and in a laboratory setting.
- Disassemble the valves from the level gauge body by unscrewing the stud bolts (1)
- Unscrew the plug (7) and (9) as a function of the valve type
- With a wooden or aluminium extension, hit the case with a knocker so that all parts that are inside may come out.
- **Warning:** the screw-tap shall not be exposed to blows or scratches, as they would compromise the valve sealing capacity
- Carefully clean the parts
- Apply the ring in two halves (5) or (12) to the screw-tap (4) or (10)
- Introduce the screw-tap into the new case (6) or (11) until it presses against the ring
- Insert the whole set into the valve body, taking care the case is driven by the dedicated slot provided in the valve body.
- Put the case-pressing cap (7) or (9) back in place.
- Move the knob a few times to check for proper rotation.
- Put the valve unit back in place on the level gauge body.
- Set the device to operate, in accordance with paragraph 5 (First Start-Up)
- Inspect the gasket during the first 24 working hours.

**YY VALVE CASE REPLACEMENT**

See paragraph 9 (suggested spare parts) for number references.

- The replacement of the stuffing box ring shall be performed with the device being disconnected from the system and in a laboratory setting.
- Disassemble the valves from the level gauge body by unscrewing the stud bolts.
- Remove the handwheel 13 by unscrewing nut 15
- Remove the plug 7 and the stuffing box retainer 9
- Replace the stuffing box ring with the new one
- Re-assemble the whole set
- Move the handwheel a few times to ensure proper rotation
- Put the valve unit back in place on the level gauge body.
- Set the device to operate, in accordance with paragraph 5 (First Start-Up)
- Inspect the gasket during the first 24 working hours.

## 8. DIMENSIONAL DRAWINGS OF THE BODY

**Key:**

- Mis. = Body measure
- INT. = Process connection axle distance
- D = Body dimension
- V = Visual part size
- C = Crystal size

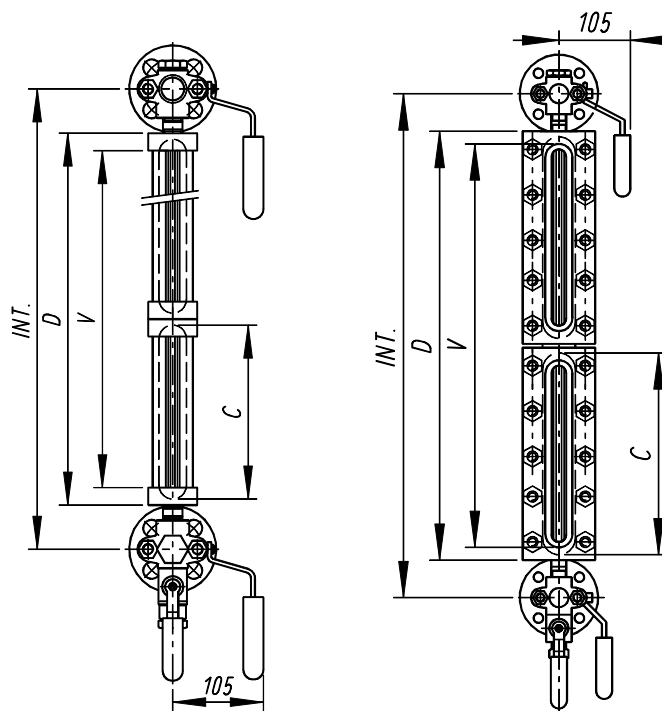
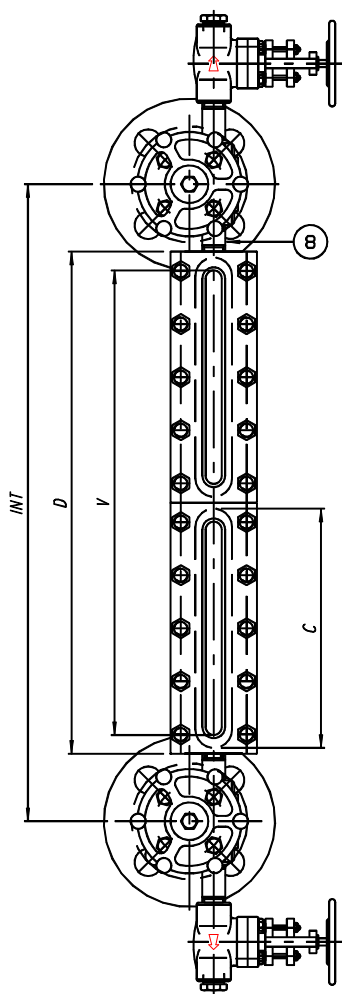

Table for model RBB						Table for models RMB and RAC					Table for model RHC				
Mis.	INT. min. (NX)	INT. min. (NY)	D	V	C	Mis.	INT. min. (NY)	D	V	C	Mis.	INT. min. (NY)	D	V	C
11	/	/	/	/	/	11	196	128	91	115	11	203	91	115	11
12	/	/	/	/	/	12	221	153	116	140	12	228	116	140	12
13	285	246	178	141	165	13	246	178	141	165	13	253	141	165	13
14	310	271	203	166	190	14	271	203	166	190	14	278	166	190	14
15	340	301	233	196	220	15	301	233	196	220	15	308	196	220	15
16	370	331	263	226	250	16	331	263	226	250	16	338	226	250	16
17	400	361	293	256	280	17	361	293	256	280	17	368	256	280	17
18	440	401	333	296	320	18	401	333	296	320	18	408	296	320	18
19	460	421	353	313	340	19	421	353	313	340	19	428	313	340	19
24	515	474	406	367	190	24	474	406	367	190	24	481	367	190	24
25	575	534	466	427	220	25	534	466	427	220	25	541	427	220	25
26	635	594	526	489	250	26	594	526	489	250	26	601	489	250	26
27	695	654	586	549	280	27	654	586	549	280	27	661	549	280	27
28	775	734	666	628	320	28	734	666	628	320	28	741	628	320	28
29	815	774	706	668	340	29	774	706	668	340	29	781	668	340	29
36	900	857	789	751	250	36	857	789	751	250	36	863	751	250	36
37	990	947	879	841	280	37	947	879	841	280	37	954	841	280	37
38	1110	1067	999	961	320	38	1067	999	961	320	38	1074	961	320	38
39	1170	1127	1059	1021	340	39	1127	1059	1021	340	39	1134	1021	340	39
47	1285	1240	1172	1134	280	47	1240	1172	1134	280	47	1247	1134	280	47
48	1445	1400	1332	1294	320	48	1400	1332	1294	320	48	1407	1294	320	48
49	1525	1480	1412	1374	340	49	1480	1412	1374	340	49	1487	1374	340	49
57	1580	1533	1465	1427	280	57	1533	1465	1427	280	57	1540	1427	280	57
58	1780	1733	1665	1627	320	58	1733	1665	1627	320	58	1740	1627	320	58
59	1880	1833	1765	1727	340	59	1833	1765	1727	340	59	1840	1727	340	59
68	2115	2066	1998	1960	320	68	2066	1998	1960	320	68	2073	1960	320	68
69	2235	2186	2118	2080	340	69	2186	2118	2080	340	69	2193	2080	340	69
79	2590	2539	2471	2433	340	79	2539	2471	2433	340	79	2539	2433	340	79

**Table for model RHH**

Mis.	INT. min.(x YY)	INT. min.(x YX)	D	V	C
11	216	265	128	91	115
12	241	290	153	116	140
13	266	315	178	141	165
14	291	340	203	166	190
15	321	370	233	196	220
16	351	400	263	226	250
17	381	430	293	256	280
18	421	470	333	296	320
19	441	490	353	313	340
24	494	543	406	367	190
25	554	603	466	427	220
26	614	663	526	489	250
27	674	723	586	549	280
28	754	803	666	628	320
29	794	843	706	668	340
36	877	926	789	751	250
37	967	1016	879	841	280
38	1087	1136	999	961	320
39	1147	1196	1059	1021	340
47	1260	1309	1172	1134	280
48	1420	1469	1332	1294	320
49	1500	1549	1412	1374	340
57	1553	1602	1465	1427	280
58	1753	1802	1665	1627	320
59	1853	1902	1765	1727	340
68	2086	2135	1998	1960	320
69	2206	2255	2118	2080	340
79	2559	2608	2471	2433	340

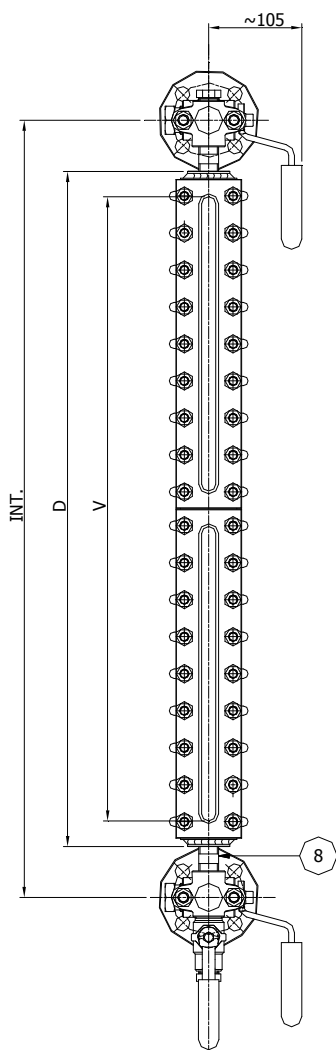
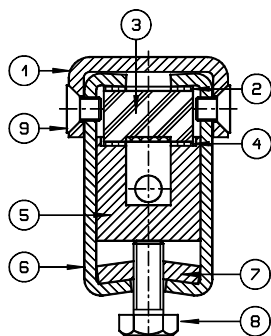

Table for model RLB				
Mis.	INT. min.(x NY)	D	V	C
12	258	168	116	140
13	283	193	141	165
14	308	218	166	190
15	338	248	196	220
16	368	278	226	250
17	398	308	256	280
18	438	348	296	320
19	458	368	313	340
24	513	423	367	190
25	573	483	427	220
26	633	543	489	250
27	693	603	549	280
28	773	683	628	320
29	813	723	668	340
36	898	808	751	250
37	988	898	841	280
38	1108	1018	961	320
39	1168	1078	1021	340
47	1283	1193	1134	280
48	1443	1353	1294	320
49	1523	1433	1374	340
57	1578	1488	1427	280
58	1778	1688	1627	320
59	1878	1786	1727	340
68	2113	2023	1960	320
69	2233	2143	2080	340

## 9. RECOMMENDED SPARE PARTS (\*) Version for series RBB



POSITION	DESCRIPTION
1	Clamping jaw
2 (*)	Protection
3 (*)	Crystal
4 (*)	Gasket
5	Body
6	Shoulder
7	Anchoring plate
8	Bolts



**Version for series RMB – RAC – RHC**

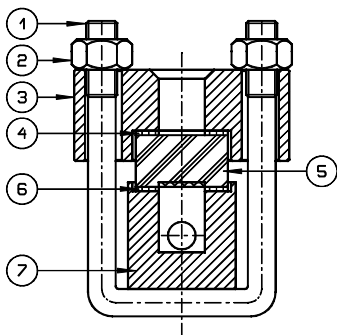

POSITION	DESCRIPTION
1	Stud Bolts
2	Nuts
3	Cover
4 (*)	Protection
5 (*)	Crystal
6 (*)	Gasket
7	Body

**Version for series RHH**

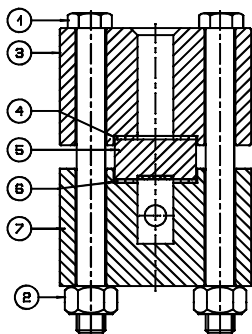

POSITION	DESCRIPTION
1	Screw
2	Nuts
3	Cover
4 (*)	Protection
5 (*)	Crystal
6 (*)	Gasket
7	Body

**Version for series RLB**

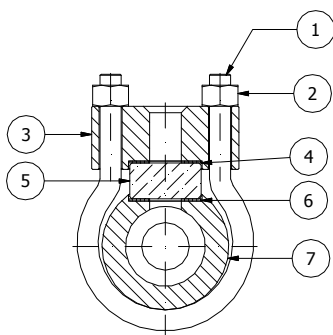

POSITION	DESCRIPTION
1	Stud Bolt
2	Nuts
3	Cover
4 (*)	Protection
5 (*)	Crystal
6 (*)	Gasket
7	Body

### Version for NY series valve assembly

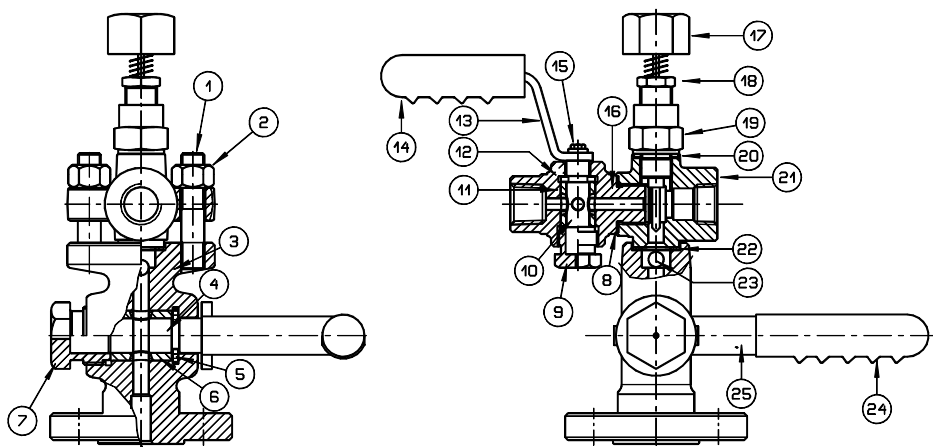

The recommended spare parts are marked with an asterisk placed beside the position. In the demand for spare parts, always indicate the equipment serial number. This number is provided in the instrument identification plate, that is fastened to the bottom of the instrument, and is a five-digit number preceded by the letter "F" (e.g.: F45678).

POS.	DESCRIPTION
1	Tie rod
2	Nut
3	Intercept valve body
4	Male size 18
5	Ring size18
6(*)	Case size 18
7	Case presser size 18
8	Gasket
9	Case presser size12
10	Male size12
11(*)	Case size12
12	Ring size12
13	Handle
14	Knob
15	Screw
16	Drain valve body
17	Separator
18	Ring Nut
19	Separator body
20	Gasket
21	Small flange body
22	Gasket
23	Safety ball
24	Knob
25	Handle

### Version for YY series valve assembly

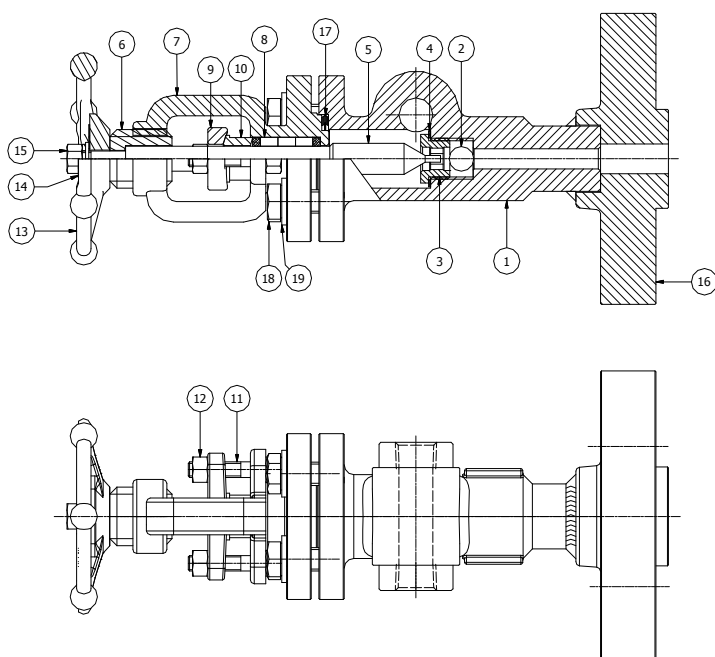

POS.	DESCRIPTION
1	Body
2	Ball check
3	Valve seat
4	Gasket
5	Spindle
6	Threaded bush
7	Bonnet
8(*)	Stuffing box ring
9	Stuffing box ratainer
10	Packing gland
11	Stud bolts
12	Nut
13	Handwheel
14	Identification plate
15	Nut
16	Connection
17(*)	Gasket
18	Body screw
19	Washer



## 10 . TROUBLESHOOTING

Level indicators of the R series are not normally exposed to faults.

**Warning:** in the event of fluid leaks, the level indicator shall be immediately intercepted. Follow the step-by-step instructions as indicated in paragraph 7 (Maintenance) to restore the instrument integrity.

## 11. DISPOSAL

When the instruments have come to the end of their service life, they need to undergo disposal. Always comply with the applicable regulations in force.

During the disposal stages, specially mind the polymers, resins and rubbers used in the manufacture (such as PVC, PTFE, PP, PVDF, neoprene, Viton, etc.).

All metal parts, after the removal of seals and gaskets, special protective coatings requested by the customer and all other plastic parts, can be recycled.

## 12. GUARANTEE

All level indicators of the R series are guaranteed to be free from manufacturing faults over a period of 12 months from the date of shipment. In the event of failures, implying return of goods within the limit specified above, Officine Orobiche will replace (**shipment fees not included**) all damaged parts free, provided that the failure does not ensue from incorrect use. Officine Orobiche shall never be held responsible for any incorrect use of their products when these are used for purposes other than those mentioned in the specifications approved at the order stage. In these cases, no complaints will ever be taken into consideration. No damage and/or fee, whether direct or indirect, ensuing from an incorrect installation or use shall ever be debited to Officine Orobiche. The instrument can be used for a maximum life period of 10 years dating from delivery.

When this period is over, there are two alternative options:

- 1) Replace it with a new instrument.
- 2) Have the old instrument overhauled by Officine Orobiche.

## INSTRUMENT RETURN PROCEDURE

The instrument returning to the factory shall bear, in attachment, the following data:

- 1) Buyer's name.
- 2) Description of the material.
- 3) Detected fault.
- 4) Process data.
- 5) Specification of the fluids that have been used with the instrument.

The instrument shall be returned perfectly clean and free from dust or deposits. Otherwise, Officine Orobiche reserves the right not to carry out the servicing and return the instrument to the sender.

## FINAL REMARKS

Each instrument is supplied fully assembled and equipped with all the needed accessories.

Some parts are sold separately under special circumstances only.

Therefore, we warn you to carefully inspect the supply and notify us at once if discrepancies are found.

**NB:** IN CASES WHEN THE DEVICES ARE INTENDED FOR USE BIS AREAS FEATURING POTENTIALLY HAZARDOUS ATMOSPHERES, THE USER SHALL STICK TO THE **ADDITIONAL SAFETY INSTRUCTIONS** ATTACHED TO THE STANDARD ONES.