

---

**INSTRUCTION MANUAL FOR FLOW METERS  
FBB SERIES****1. INSTRUMENT DESCRIPTION**

Diaphragm flow meters of the gauged flange type, with parallel-connected flow switch for big air flows.

**2. MODEL IDENTIFICATION**

The instrument is identified through a model code.

To learn the coding more in detail, please look into the catalogue bulletin.

**3. OPERATING PRINCIPLE**

The flow meter exploits the gauged-flange diaphragm principle.

It is made of a tapered pipe inside which a float is free to run.

On the outside of the pipe, a graduated scale is located, the fluid rate is directly read on the scale, by the line that is shown in the figure beside.

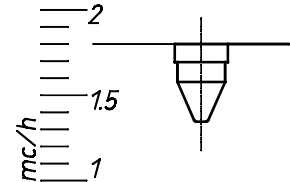
**4. INSTALLATION**

Before effecting the setup to remove the protections on the body it brings diaphragm and to verify the compatibility between the connections of line and the flange set of the instrument.

The inner diameter of the piping and that of the diaphragm (1) shall be identical to ensure measurement accuracy.

Use standardized seals, **moreover the latter shall not skirt within.**

For proper operation upstream and downstream of the unit, some straight segments of piping shall be found equal to at least 2 times DN (piping bore). **For a correct installation you see the enclosure A.**

Advice for proper service performance:

- Apply inlet and outlet valves to cut the instrument off in the event of maintenance.
- In the event of the flow meter having to remain inoperative for a long time, cut off and drain the flow meter.
- In the event of the instrument having to remain inoperative for a long time, before re-using it, carefully clean the inner through-holes by means of non-abrasive tools (e.g. compressed air).

**5. SETTING AT WORK (Fig.1)**

The flow meter body shows an arrow with the direction of the flow, which shall be followed at the assembling stage for proper operation.

To change the diaphragm position, unscrew the four screws (2) and turn the diaphragm (1) to the desired position, then screw back the four screws with a drop of Loctite 542 taking care not to damage the seal (3)(4).

After fitting the unit on the line, take the following steps:

- VENT : unscrew the upper wheel (5) so that all the air that is in the instrument comes out, until a small amount of water comes out; you do not need to pull it all out, simply loosen it..
- Once the instrument is vented, screw back the upper wheel.
- The side plates **SHALL BY NO WAY** be removed when the instrument is operating.

**6. CALIBRATION**

The instrument is factory-set and does not require any calibration to be performed on site.

**7. MAINTENANCE (Fig. 1)**

As regards instruments that are meant to measure fluids that are likely to leave deposits, we suggest you carry out a routine cleaning of the measuring pipe and the float.

- Ensure the instrument is cut off and drained of all liquid.
- Slowly loosen the upper wheel (5) to discharge all pressures.
- Unscrew the four screws (6) and remove the side plates (7).
- Pull out the upper head piece (8) and the retainer (9).
- Remove the measuring pipe (10) with the float (11).
- Pull out the inner pipe (12).
- Check the seals (3-4-14 -15) to ensure they are intact, their wear might cause some fluid to leak out of the flow meter.
- Clean all parts (float, pipe, inner pipe) with an aerograph and/or non-abrasive tools.

## INSTRUCTION MANUAL FOR FLOW METERS FBB SERIES

- Visually inspect the float and the inside of the pipe, make sure the pipe has not brought about any corrosion or erosion, as these may lead to precision errors of the instrument and, in the long run, to damages.
- In cases when there are damaged parts, immediately replace them, and contact our customer service for the related spare parts.
- Once the cleaning is over and any damaged parts are replaced, fit the parts back in place, taking care not to damage the pipe seal (16).
- To start up the instrument, please comply with the instructions provided in paragraph 5. **SETTING AT WORK.**

Fig. 1

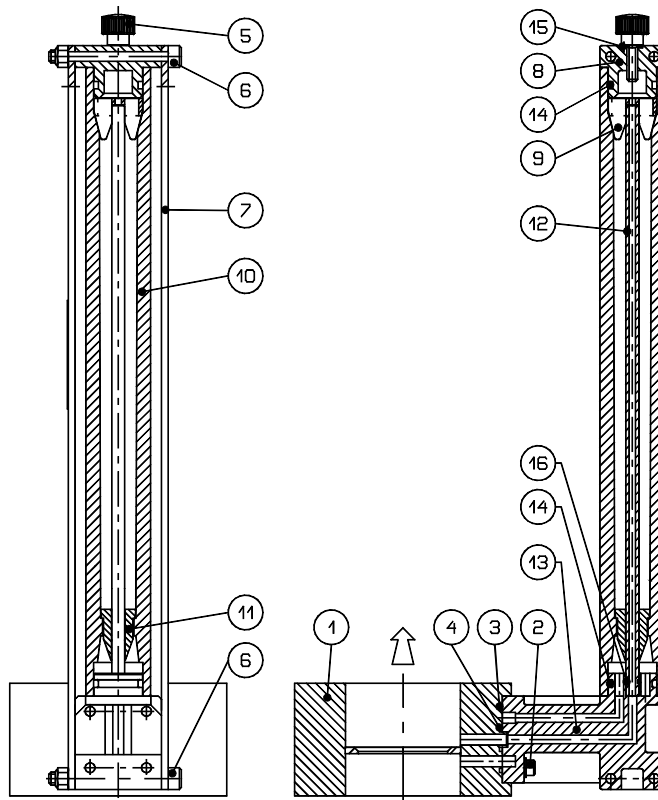

### 8. RECOMMENDED SPARE PARTS (Fig. 2)

- In the event of routine cleaning, replace the set of seals, including:

- No. 1 O-Rings seal (3) that couples the diaphragm to the flow meter.
- No. 1 O-Rings seal (4) that couples the diaphragm to the flow meter.
- No. 2 O-Rings seal for measuring pipe (14).
- No. 1 O-Rings seal of inner pipe (16).
- No. 1 flat seal of upper wheel (15).

- In case of breakage of parts of the flow meter (except for the seals), replace the complete part (PC).

**Note:** On ordering spare parts, always indicate the rating ( DN ) and its maximum rate ( Q ), as specified on the instruments rating plate.

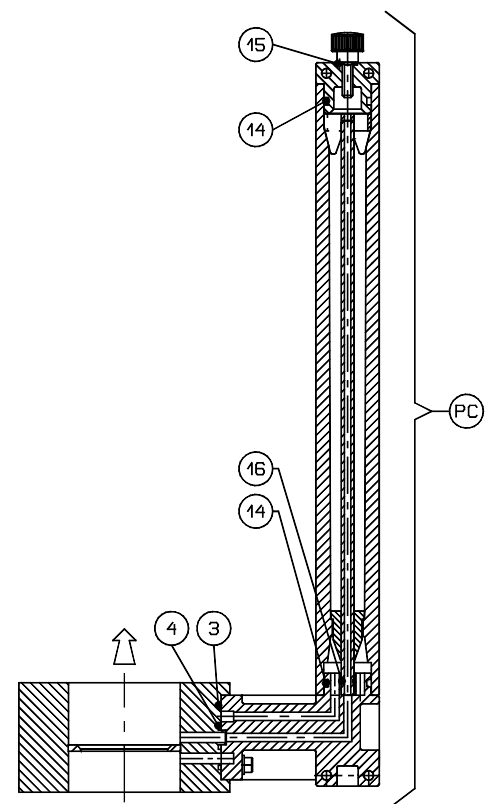

Fig.2



---

**INSTRUCTION MANUAL FOR FLOW METERS  
FBB SERIES**

**9. TROUBLESHOOTING**

Flow meters of the FBB series are not normally exposed to faults.

- If the flow meter does not take a correct measurement; inspect the pipe and the float.
- If some fluid leaks out of the head pieces; checks the seals to ensure they are intact.
- If some liquid leaks out of the upper wheel; check the seal for integrity and the tightening.
- great variation of range; to verify that the diaphragm gasket are mounted centered

All these checks shall be performed by following the instructions provided in paragraph **7. MAINTENANCE**.  
If the problem persists or for other inconveniences whatsoever, please contact our customer service.

**10. DISPOSAL**

When the instruments have come to the end of their service life, they need to undergo disposal. Always comply with the applicable regulations in force.

During the disposal stages, specially mind the polymers, resins and rubbers used in the manufacture.

All metal parts, after the removal of seals and gaskets, special protective coatings requested by the customer and all other plastic parts, can be recycled.

**11. GUARANTEE**

All flow meters of the FBB series are guaranteed to be free from manufacturing faults over a period of 12 months from the date of shipment.

In the event of failures, implying return of goods within the limit specified above, the supplier will replace (shipment fees not included) all damaged parts free, provided that the failure does not ensue from incorrect use.

The supplier shall never be held responsible for any incorrect use of their products when these are used for purposes other than those mentioned in the specifications approved at the order stage.

In these cases, no complaints will ever be taken into consideration.

No damage and/or fee, whether direct or indirect, ensuing from an incorrect installation or use shall ever be debited to supplier.

The instrument can be used for a maximum life period of 10 years dating from delivery.

When this period is over, there are two alternative options:

- 1) Replace it with a new instrument.
- 2) Have the old instrument overhauled by the supplier or, at all events, by a qualified technician who undertakes to guarantee any further use of the unit.

**INSTRUMENT RETURN PROCEDURE**

The instrument returning to the factory shall bear, in attachment, the following data:

- 1) Buyer's name.
- 2) Description of the material.
- 3) Detected fault.
- 4) Process data.
- 5) Specification of the fluids that have been used with the instrument.

The instrument shall be returned perfectly clean and free from dust or deposits. Otherwise, the supplier reserves the right not to carry out the servicing and return the instrument to the sender.

**FINAL REMARKS**

Each instrument is supplied fully assembled and equipped with all the needed accessories.

Some parts are sold separately under special circumstances only.

Therefore, we warn you to carefully inspect the supply and notify us at once if discrepancies are found.

## INSTRUCTION MANUAL FOR FLOW METERS FBB SERIES

### ENCLOSURE A

#### VERTICAL ASSEMBLY

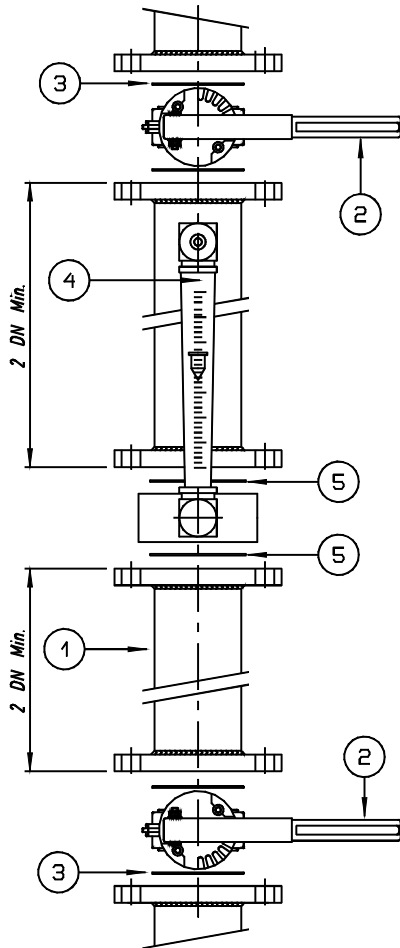

DENOMINATION	
1	TUBE
2	VALVE
3	VALVE GASKET
4	FLOWMETER
5	FLOWMETER GASKET

#### HORIZONTAL ASSEMBLY

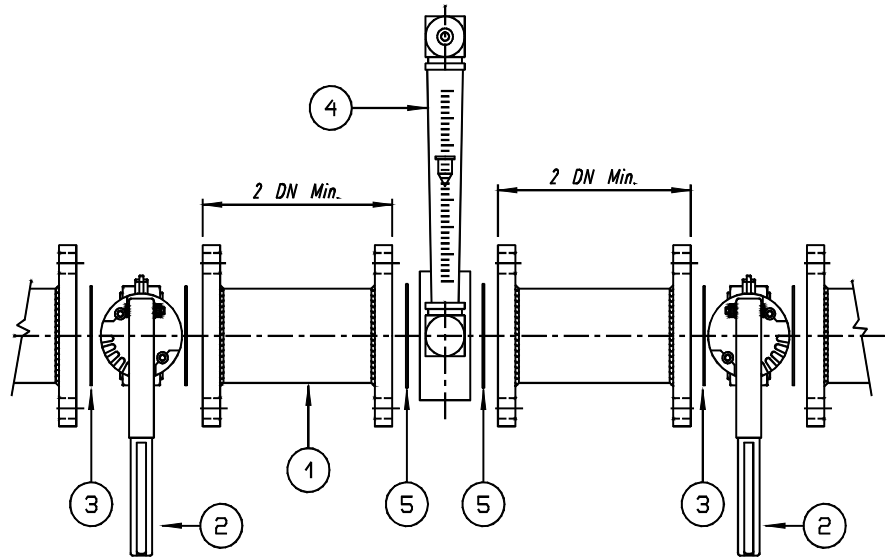

PIPE TO UTILIZE	
DN	DIMENSIONS
40	Ø48.3 Sp.3.2
50	Ø60.3 Sp.3.6
65	Ø76.1 Sp.2.6
80	Ø88.9 Sp.2.9
100	Ø114.3 Sp.3.2
125	Ø139.7 Sp.3.6
150	Ø168.3 Sp.4
200	Ø219.1 Sp.5
250	Ø273 Sp.6.35
300	Ø323.9 Sp.6.35

The flowmeter must be mounted right.  
The function of the outlet-valve is also back pressure valve.