

INSTRUCTION MANUAL MAGNETIC sensors for instruments series 2000

1. INSTRUMENT DESCRIPTION

Magnetic switches are used to be fitted to the external sides of level indicators of the 2000 series and are equipped with a single exchange contact (SPDT). They provide a maximum and/or minimum level alarm signal on the level indicator.

They are connected to the indicator through stainless steel straps and can be adjusted to whatever position you desire.

Magnetic switches are designed to provide simple and lasting service.

They are unfed bistable switches and are mainly composed of a housing with an incorporated reed contact which is actuated by the magnetic field.

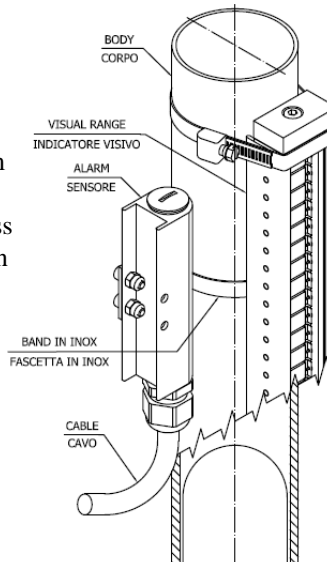

Fig. 1



2. MODEL IDENTIFICATON

<p>T25 T25 INOX</p>	<p>Sensor for ambient temperatures within the $-50^{\circ}\text{C}/+7\ 0^{\circ}\text{C}$ Media temperature up to $250\ ^{\circ}\text{C}$ Protection class IP 66</p> <p>CONTACT RATING 230 VAC / 1A / 40VA – 200 VDC / 0,5A / 40W</p>
<p>T25 XI T25 XI INOX</p>	<p>Sensor for ambient temperatures within the $-50^{\circ}\text{C}/+7\ 0^{\circ}\text{C}$ Media temperature up to $250\ ^{\circ}\text{C}$ Protection class IP 66</p> <p>Atex marking II 2G Ex ia IIC T6...T4 Gb II 2D Ex tb IIIC T85°C...T135°C Db</p> <p>IECEX marking Ex ia IIC T6...T4 Gb Ex ia IIIC T85°C...T135°C DbEAC Ex</p> <p>SIL 2</p> <p>CONTACT RATING U_i = 28V - I_i = 100 mA - Li = negligible Ci = negligible - Pi = 700 mW</p>
<p>T25 XD T25 XD INOX</p>	<p>Sensor for ambient temperatures within the $-40^{\circ}\text{C}/+7\ 0^{\circ}\text{C} / -50^{\circ}\text{C}/+70^{\circ}\text{C}$ Media temperature up to $250\ ^{\circ}\text{C}$ Protection class IP 66</p> <p>Atex marking II 2G Ex db IIC T6...T4 Gb II 2D Ex tb IIIC T85°C...T135°C Db</p> <p>IECEX marking Ex db IIC T6...T4 Gb Ex tb IIIC T85°C...T135°C DbEAC Ex</p> <p>SIL 2</p> <p>CONTACT RATING 230 VAC / 1A / 40VA – 200 VDC / 0,5A / 40W</p>
<p>T25 WH</p>	<p>Sensor for ambient temperatures within the $-50^{\circ}\text{C}/+7\ 0^{\circ}\text{C}$ Media temperature up to $250\ ^{\circ}\text{C}$ Protection class IP 66</p> <p>CONTACT RATING 230 VAC / 1A / 40VA – 200 VDC / 0,5A / 40W</p>
<p>T25 WHXI</p>	<p>Sensor for ambient temperatures within the $-50^{\circ}\text{C}/+7\ 0^{\circ}\text{C}$ Media temperature up to $250\ ^{\circ}\text{C}$ Protection class IP 66</p> <p>Atex marking II 2G Ex ia IIC T6...T4 Gb</p> <p>IECEX marking Ex ia IIC T6...T4 GbEAC Ex</p> <p>SIL 2</p> <p>CONTACT RATING U_i = 28V - I_i = 100 mA - Li = negligible Ci = negligible - Pi = 700 mW</p>
<p>T25 HT</p>	<p>High temperature sensor for ambient temperatures within the $-50^{\circ}\text{C}/+70^{\circ}\text{C}$ Media temperature up to $350\ ^{\circ}\text{C}$ Protection class IP 66</p> <p>CONTACT RATING 230 VAC / 1A / 40VA – 200 VDC / 0,5A / 40W</p>



T25 HTXI	<p>High temperature sensor for ambient temperatures within the $-50^{\circ}\text{C}/+70^{\circ}\text{C}$ Media temperature up to 350°C Protection class IP 66 Atex marking II 2G Ex ia IIC T6...T4 Gb EAC Ex SIL 1</p> <p>CONTACT RATING $U_i = 28\text{V} - I_i = 100\text{ mA} - L_i = \text{negligible} - C_i = \text{negligible} - P_i = 700\text{ Mw}$</p>
T25 NR	<p>Sensor for ambient temperatures within the $-50^{\circ}\text{C}/+7^{\circ}\text{C}$ Media temperature up to 250°C Protection class IP 66 ATEX marking Intrinsically safe IECEx marking Intrinsically safe</p> <p>NAMUR output</p>
T25 PN	<p>Sensor for ambient temperatures within the $-15^{\circ}\text{C}/+6^{\circ}\text{C}$ Protection class IP 65 Pneumatic switch</p> <p>CONTACT RATING $0 / 40\text{ psi}$</p>
T25 XD2	<p>Sensor for ambient temperatures within the $-40^{\circ}\text{C}/+7^{\circ}\text{C}$ Media temperature up to 250°C Protection class IP 66 Atex marking II 2G Ex db IIC T6 Gb II 2D Ex tb IIIC T 85°C Db IECEx marking Ex db IIC T6 Gb Ex tb IIIC T 85°C DbEAC Ex SIL 2</p> <p>CONTACT RATING $230\text{ VAC} / 1\text{A} / 40\text{VA} - 200\text{ VDC} / 0,5\text{A} / 40\text{W}$</p>

3. OPERATING PRINCIPLE

Magnetic switches are used to provide a switching function at a preset level on level indicators or similar instruments and can be mounted, one or more, on each individual level indicator.

Magnetic switches of the T25 XI, T25 WHXI, T25 XD, T25 XD2 and T25 HTXI models comply with the ATEX certificate of suitability (see attached) as a device that is suitable for use in the presence of a potentially explosive atmosphere, magnetic switches of the T25 XI, T25 WHXI, T25 XD and T25 XD2, models comply with IECEx certificate as well.

The use of magnetic switches with inductive or capacitive loads may damage switches. This might cause the control to malfunction in the process and thus cause damages to the system.

With an inductive load, protect magnetic switches with an RC type module or with a shunt diode. The use of varistors as a protection is not advisable for the reed contact as it could be destroyed by the starting peaks.

With a capacitive load, use cable longer than 50m, or serially connect a 22 Ohm protective resistor to the common connection to restrict the current peak.

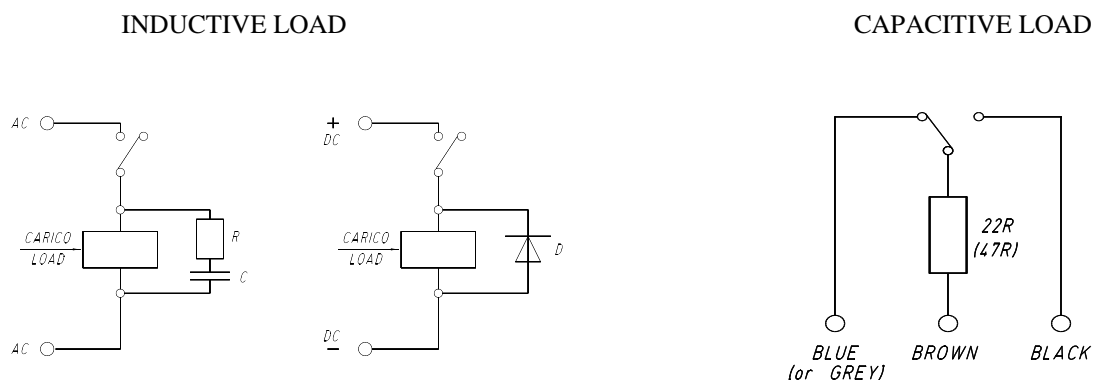

4. INSTALLATION

4.1 MOUNTING

Before mounting the magnetic switch, make sure it suits the type of environment in which it is used (e.g. for use in an area featuring risks of explosion, please provide form T25 XD, T25 XD2, T25 WHXI, T25 XI or T25 HTXI).

Magnetic switches supplied along with level indicators are already pre-assembled and shall only be located at the desired switching height.

Check that the cable entrance is downward or sideward.

To guarantee a correct switching function, the magnetic switch shall stay close to the body tube of the level indicator so that it senses the magnetic field of the magnet located inside the float.

Magnetic switches only operate in the area between the connections of the level indicator with the process and, hence, cannot be located outside this area.

Do not operate them close to strong electromagnetic fields (minimum distance: 1m) and do not expose them to mechanical loads.

IMPORTANT

Magnetic sensors are designed to be mounted on magnetic level gauge, bypass chamber to work properly shall be mounted in vertical position so magnetic sensors are mounted in side position respect to the chamber itself (see Fig.1).

Sensor distance from bypass chamber is fixed by the bracket that is part of the sensor itself. Temperature limits are guaranteed when the sensor is mounted with own bracket, do not demount or release the bracket in order to maintain working temperature limits, no thermal insulation is needed. To adjust sensor position simply release the band and move vertically the sensor to the desired position.

Notes for Environments featuring explosions risks (Ex)

Ensure the sensor suits the classification of the area, and the characteristics of flammable substances that can be found on the system.

Operate in such a manner as to absolutely avoid causing sparks, there where an air-gas burning mixture is found in the environment.

Working in this area is prohibited unless the person is not qualified.

Safety measures shall be taken to avoid harming individuals and damaging the structure.

See “Additional Safety Instruction” for more information.**4.2 ELECTRICAL WIRING**

The connection shall be made in accordance with the wiring diagram with at least 3 x 0.75 mm² cables depending on the desired switching function. In selecting the cable, take care it suits the envisaged application field (see temperature, weather influences, aggressive atmosphere etc.).

Magnetic switches shall be connected in accordance with the laws in force in the country of installation, and mind the power supply data.

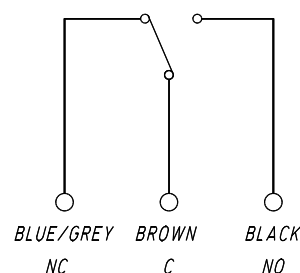
**Notes for environments featuring explosion risks (Ex)**

The connections shall be made through cable entrances or tube piping in compliance with the EN 60079-14 standard.

The cable entrance shall not affect the specific properties of the protection method as indicated in the EN 60079-1. When the cable inlet is made by using a cable gland, the latter shall be correctly chosen as a function of the system type and of the cable type. The cable gland shall be screwed tight to allow the sealing rings to exert the required pressure.

The ground connection must be connected to the general system ground with a conductor of suitable section (normally the same section as the mains connection).

5. SETTING AT WORK

Make sure that the instrument is not used beyond the allowed limits (e.g. temperatures) and that the electrical rating applied complies with the technical data.

Before operating them, locate the magnetic switches at the desired heights and make the float of the level indicator slide slowly inside the tube bottom up. After that, make it run down slowly. If this is not possible, carry out the operation by making them float, with the magnet on the top, beside the magnetic switch. If no float is available, you may even use a permanent magnet with radial polarity.

Ensure the instrument correctly performs the switching by varying the level inside the indicator a few times.

6. CALIBRATION

The functional test is meant to assess correct operation of the reed type contacts.

Disconnect the power supply connection before carrying out the test. To rate the switching, use a continuity tester or similar units.

Since magnetic switches are bistable, they demand a given initial condition before being operated, otherwise the switching function risks to become faulty and engages a false position of the contact in the process control.

Notes for Environments featuring explosion risks (Ex)

The testing equipment for the functional test shall be appropriate or certified for use in dangerous areas. Only qualified persons can carry out this work. The competent technical staff shall connect and disconnect the electrical lines.

Notes for Model T25 HT Sensor

During the calibration stage, it being understood that the position along the axis is at the discretion of the installer, the radial position shall be the one opposite the rod that holds the Reeds as shown in Fig. 2.

7. MAINTENANCE

Magnetic sensors do not generally demand scheduled maintenance.

Periodically check the contact, about once every six months, for proper operation.

Notes for Environments featuring explosions risks (Ex)

Tests and maintenance over explosion proof sensors T25 XD or T25 XD2 shall be carried out according to the criteria set forth in the EN 60079-17 standard.

- Terminals and wiring shall be well tightened to avoid overheating.
- All replacement parts shall be original spare parts.
- Repairs of broken parts are not allowed.

7.1 NOTICES

- DO NOT operate on the sensor without first being sure that voltage has been disconnected;
- NEVER use the sensor at a temperature that exceeds the rating;
- NEVER use the sensor with an electrical rating that exceeds the rating;
- In the case of an instrument used with high temperatures, take all the measures required to guarantee the protection to the service staff during maintenance stages.

7.2 REPLACEMENT and/or SETTING OF THE OPERATION POINT

Unscrew the fastening screw and move the magnetic switch to the level of the switching point or replace the magnetic switch in cases when it is broken. Once the positioning is over, tighten the screw and repeat the operations described in paragraphs 5 and 6.

8. DIMENSIONAL DRAWINGS OF THE BODY

Model T25
Model T25 XD
Model T25 XI

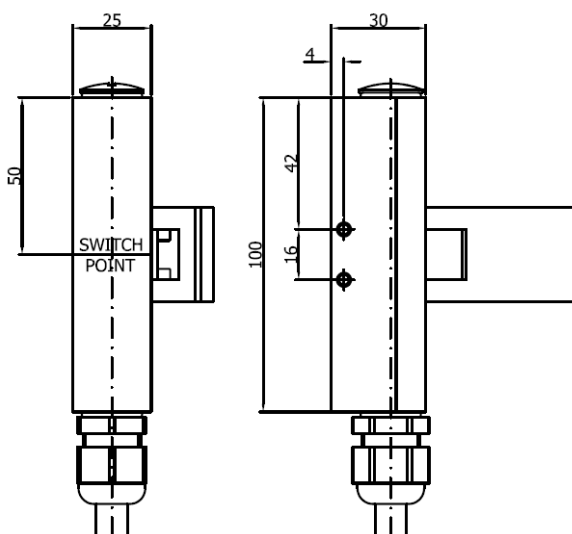

Model T25 HT

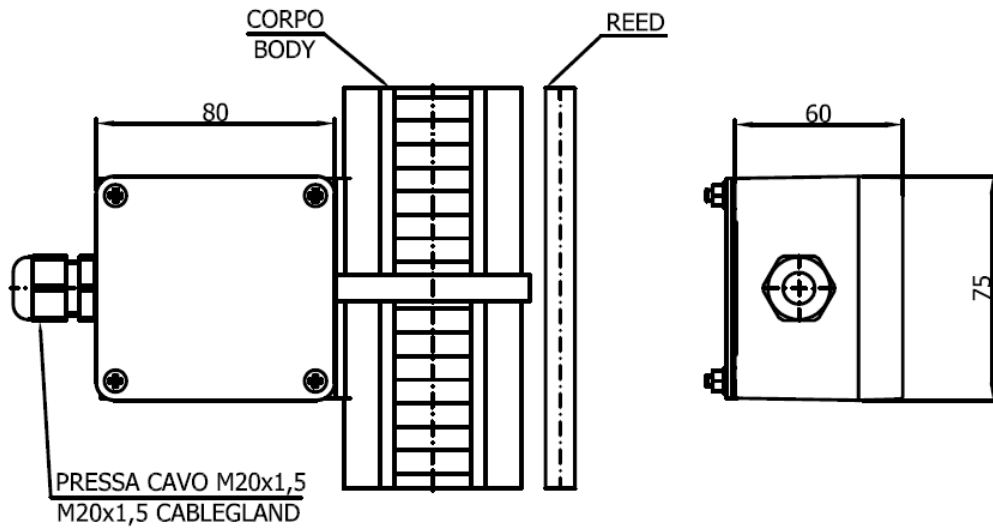
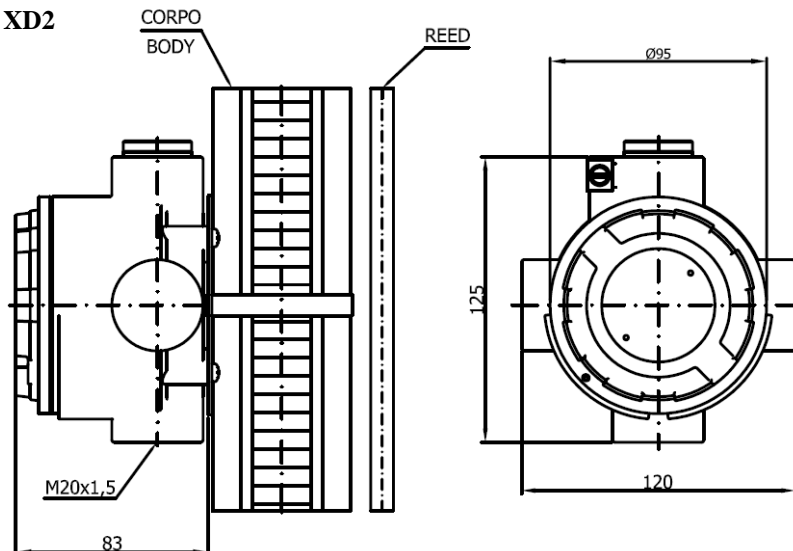

Fig. 2



Model T25 XD2



Model T25 PN

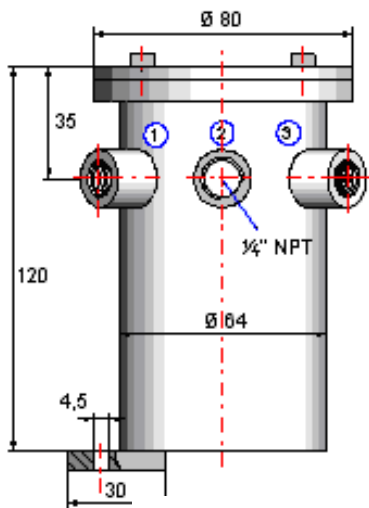

Model T25 WH – T25 WHXI

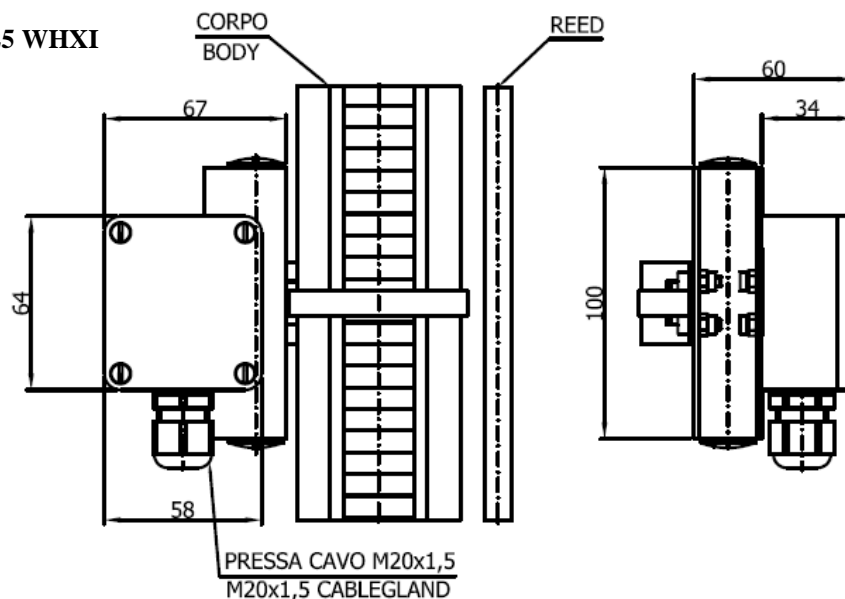

9. PROTECTIVE MODULES of the RC type

Use the RC protective modules according to the table below. The rating of switches and the reference voltage will define the type of module to adopt. Other types can destroy or damage the reed service life over time.

For 60 VA reed contacts

Capacity	Resistance	Voltage
0,33 μ F	47 Ohm	24 V~
0,33 μ F	100 Ohm	48 V~
0,33 μ F	470 Ohm	115 V~
0,33 μ F	1000 Ohm	230 V~

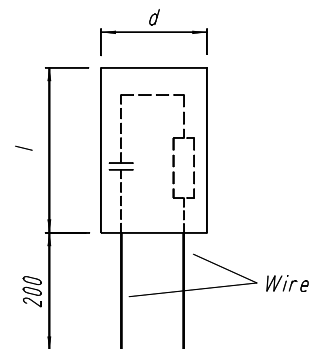



10. SPARE PARTS

Always mention the instrument serial number in your request for spare parts.
This number is provided on the instrument rating plate that is fastened to the housing and is a five-digit number preceded by the letter "F"(e.g.:F45678).

11. FAULT FINDING

Magnetic switches are not normally exposed to faults.
In cases when the level switch does not operate the switching, carry out the test indicated in paragraph
The magnetic switch cannot be repaired and in case of breakage, it must be replaced.

12. DISPOSAL

When the instruments have come to the end of their service life, they need to undergo disposal. Always comply with the applicable regulations in force.
During the disposal stages, specially mind the polymers, resins and rubbers used in the manufacture (PVC, PTFE, PP, PVDF, neoprene, viton, etc.).
All metal parts, after the removal of seals and gaskets, special protective coatings requested by the customer and all other plastic parts, can be recycled.

13. GUARANTEE

All the magnetic switches are guaranteed to be free from manufacturing faults over a period of 12 months from the date of shipment.
In the event of failures, implying return of goods within the limit specified above, OFFICINE OROBICHE will replace (shipment fees not included) all damaged parts free, provided that the failure does not ensue from incorrect use.
OFFICINE OROBICHE shall never be held responsible for any incorrect use of their products when these are used for purposes other than those mentioned in the specifications approved at the order stage.
In these cases, no complaints will ever be taken into consideration.
No damage and/or fee, whether direct or indirect, ensuing from an incorrect installation or use shall ever be debited to OFFICINE OROBICHE.
The instrument can be used for a maximum life period of 10 years dating from delivery.
When this period is over, there are two alternative options:
1) Replace it with a new instrument.
2) Have the old instrument overhauled by OFFICINE OROBICHE.

INSTRUMENT RETURN PROCEDURE

The instrument returning to the factory shall bear, in attachment, the following data:
1) Buyer's name.
2) Description of the material.
3) Detected fault.
4) Process data.
The instrument shall be returned perfectly clean and free from dust or deposits. Otherwise, OFFICINE OROBICHE reserves the right not to carry out the servicing and return the instrument to the sender.

FINAL REMARKS

Each instrument is supplied fully assembled and equipped with all the needed accessories.
Some parts are sold separately under special circumstances only.
Therefore, we warn you to carefully inspect the supply and notify us at once if discrepancies are found.