



**INSTRUCTION MANUAL
TLQ-xxW Series Level Gauge**

1. MODEL IDENTIFICATION

MODEL	TYPE	
TLQ	37W	90° returne idlers and float for floating roof
	38W	90° returne idlers and float
	39W	90° returne idlers for floating roof
	40W	90° returne idlers and float with liquid seal
	41W	Sealed pulley and float

2 ASSEMBLING

2.1 TLQ-38W ASSEMBLING

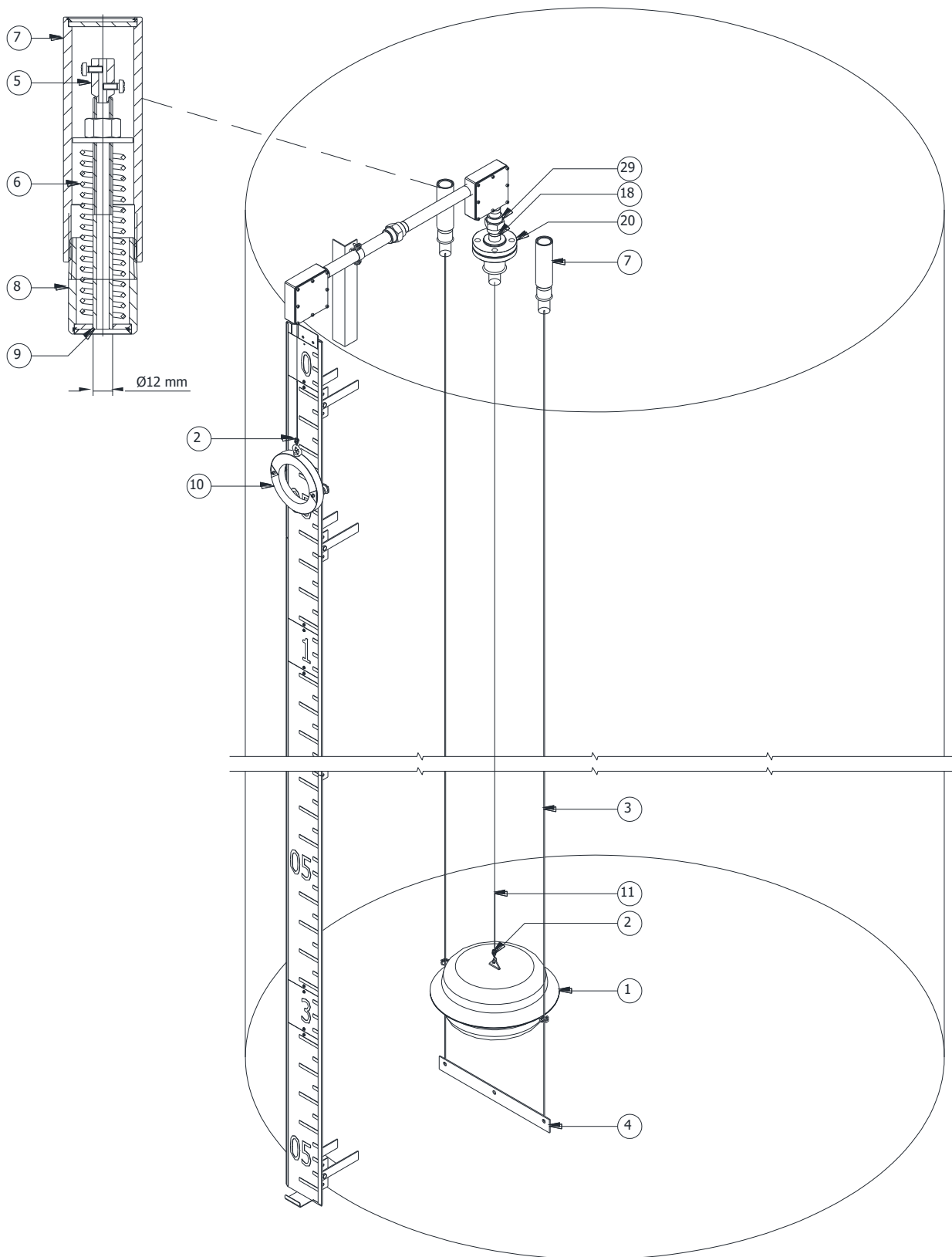

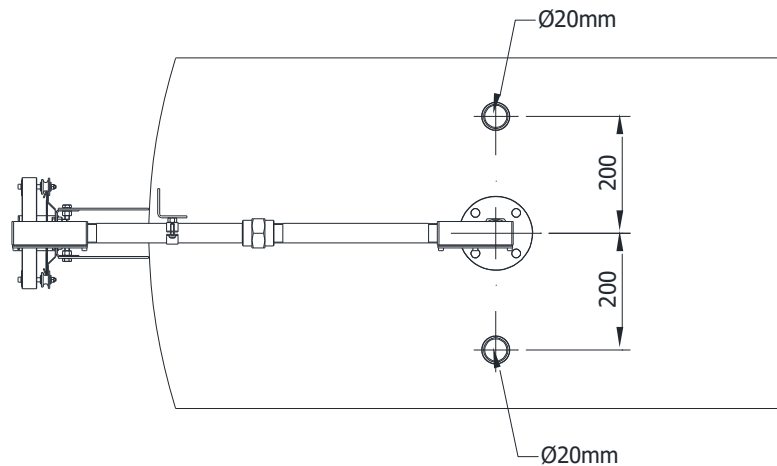
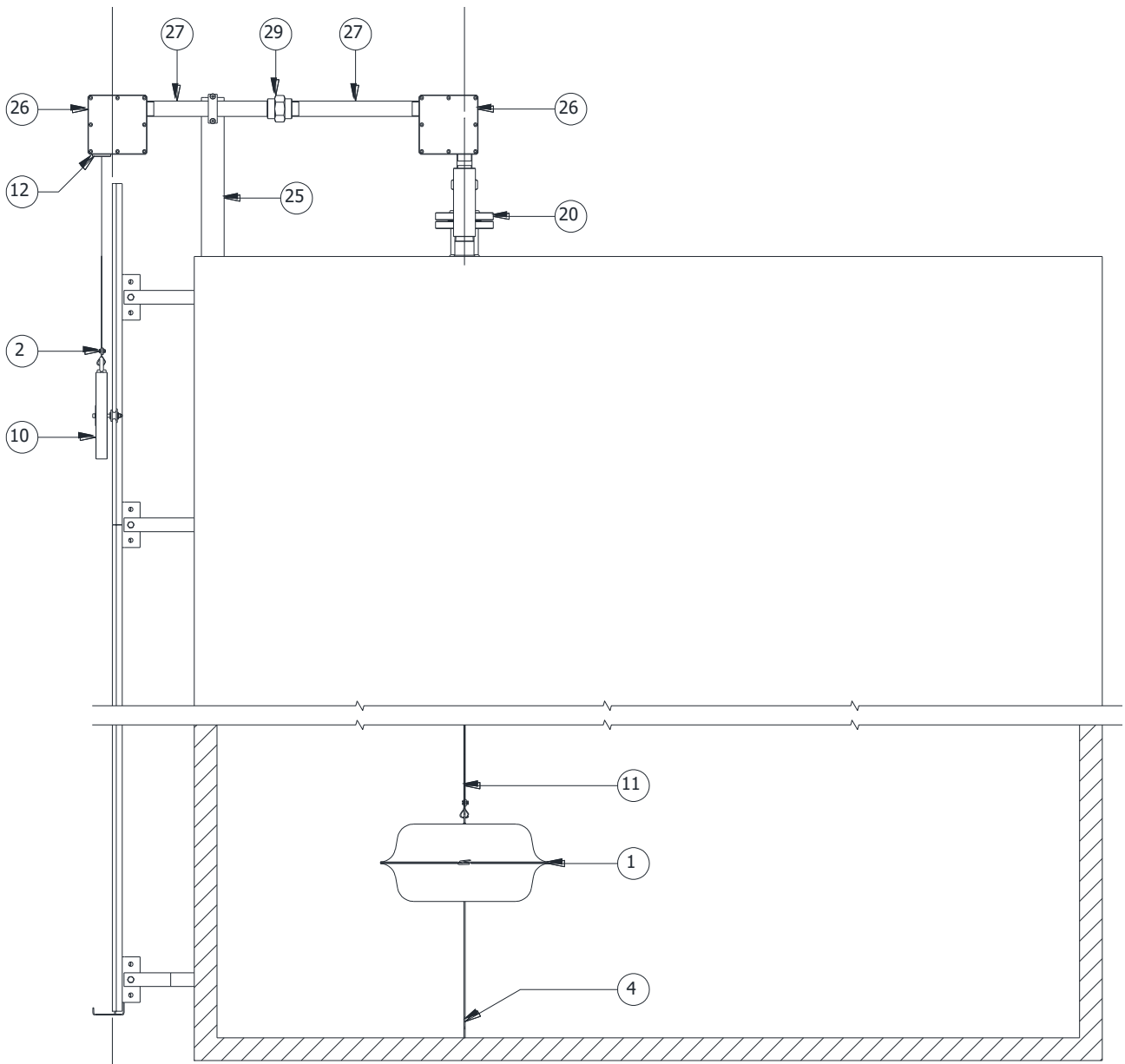

1	Float
2	Clamp
3	Guide wire
4	Anchoring bar
5	Clamp
6	Spring
7	Spring tightening
8	Connection
9	Rope guide
10	Index
11	Rope
12	Wire-guide
18	Connection pipe
20	Flange
25	Pipe bracket
26	90° return idlers
27	Connection pipe
29	Fitting

2.1.1 Anchoring bar and spring tightening

Prepare two holes for spring tightening (7) on the sides of the flanged nozzle.

Define the position of the anchor bar (4) lowering two plumb wires from the holes created for the spring tightening.

Weld the anchor bar (4) at the bottom of the tank.

Welding the tensioner fittings (8) to the two holes previously created on the tank's roof.

In special executions the tensioners can be, instead of welded, threaded or flanged. The nozzle could be threaded and not flanged.

2.1.2 90° return idlers

Place the flange (20) with the connection pipe (18) and the fitting (29) on the flanged (or threaded) nozzle. Mount and orient, as shown in the previous drawing, the 90° return idlers (26) connected by the connection pipes (27) and the fitting (29).

Weld the bracket (25) to the tank's roof then connect the connection pipe (27) to the bracket (25).

2.1.3 Tensioners and float

To perform the following operations you need at least two operators: one on the tank's roof and one on the bottom, inside the tank.

Insert one guide wire's end (3) in the tank, passing through of one of the spring tightening' connection (7) until it reaches the tank's bottom.

Slide one guide wire's end (3) through the anchor bar's holes (4) as shown in the following picture:

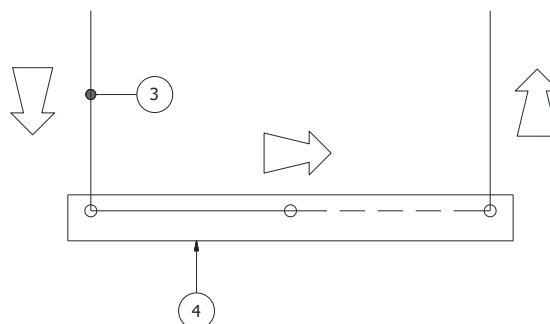



Bend the guide wire's end (3) in order to form a small hook (it's going to be used to lift the wire to the tank's roof and it's going to be cut).
From the tank's top, insert another wire through the other spring tightening (7) and lower it to the tank's bottom.
Tie the thread just lowered to the hook made on the guide wire (3).
From the tank's top pull the wire so as to lift the guide wire (3) until it passes through the spring tightening (7), then cut the hook of the first guide wire (3).
Insert the springs (6) at the two guide wire's end (3) and in coupling (8).
Insert wire guides (9) and wire clamps (5) in the spring.
Pull the two the guide wire's end (3) at the same time with two pliers to remove all bend from the guide wire.
Keeping the wire tensioned, attach the clamps (5) to the guide wire (3).
Adjust the tension of the wire (3) by turning the two nuts against the spring (6).
Place the float (1) within the tensioner guide wire (3) and lay it on the anchor bar (4).
Remount the spring tighteners (7).

The just described step can be done in many other ways but, in any case, we suggest to not split the guide wire because is to may detach from the anchor bar.

2.1.4 Graduate scale

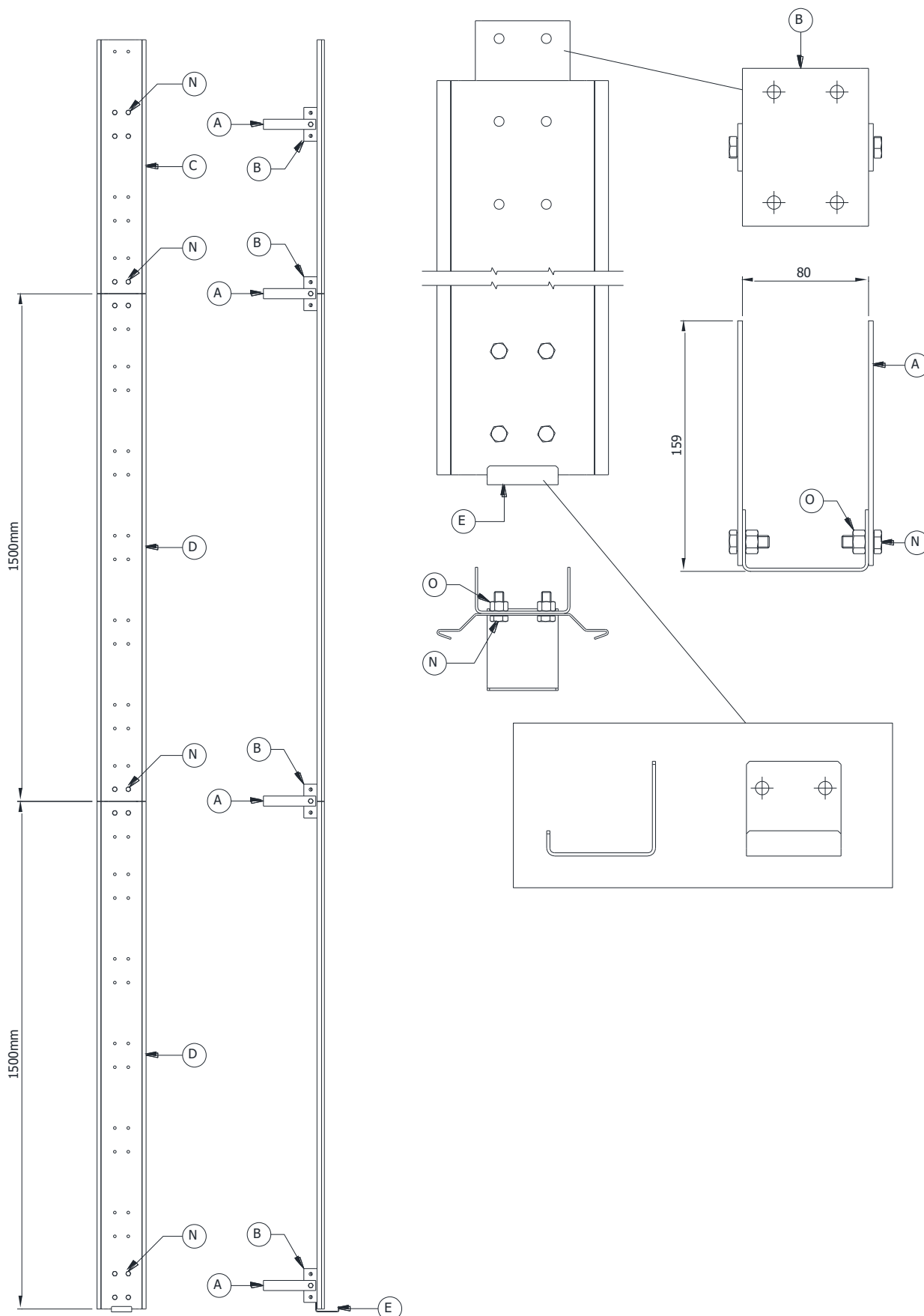

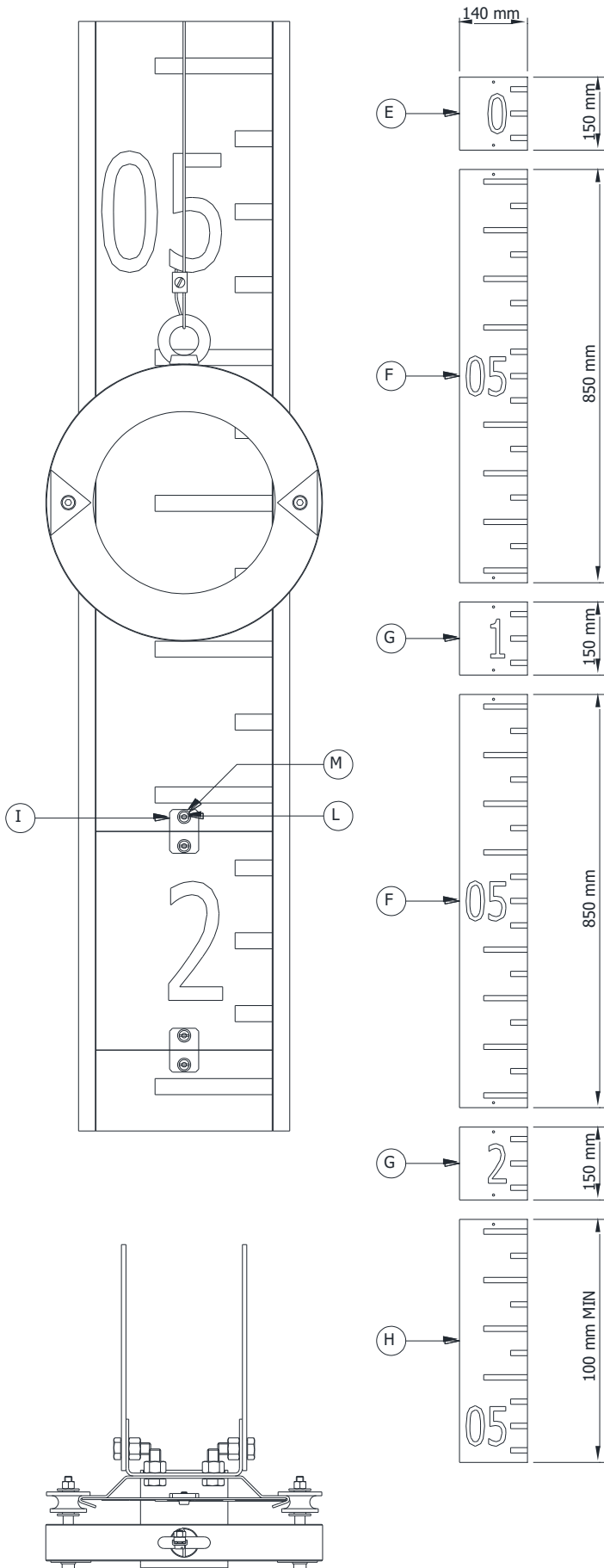

A	Brackets
B	Junction bracket
C	Final guide
D	Guide
E	Stopper
F	"05" Element
G	Number element
H	Final element
I	Junction plate
L	Screws
M	Washers
N	Screws
O	Nuts

Drop a plumb line from the wire guide (12) to define the graduated scale's position.

The scale must be centered with the plumb line when seen from the front and it shall be positioned about 3 cm behind the plumb line when viewed from the side.

Check that the brackets' length (A) is correct in order to respect this distance, otherwise they should be shortened or additional supports should be provide.

Determine the brackets' correct position and weld them to the tank. To ease this step it may be useful to mount the brackets before the welding, to mark their correct position on the tank, unscrew them and then to weld them in the marked points.

Begin to mount the graduated scale's guide from the tank's bottom by connecting the bottom of a guide (D) at the stopper (E) through the junction support (B) then screw the junction support (B) to the brackets (A) welded to the tank using screws (N) and nuts (O).

Connect the top of the start guide (D) to another guide (D) using the junction support (B) as previously done, and screw the junction support (B) to the brackets (A) welded to the tank.

Proceed in this way also for the further intermediate guides until the completion of the guide for the graduated scale with the final guide (C). The highest junction support (B) shall be placed in the most suitable position behind the final guide (C).

Insert the graduated scale in the guide, remembering that the numbers are in ascending order from top to bottom.

From bottom to top the pieces shall be assembled in this order:

1. Final element (H)
2. Number element (G)
3. "05" Element (F)
4. Repeat steps 2 and 3 up to the number "0" (E).

The scale's elements shall be connected to each other by screwing them to the junction plates (I) placed behind the elements with the appropriate screws (L) and washers (M).

2.1.6 Index and rope

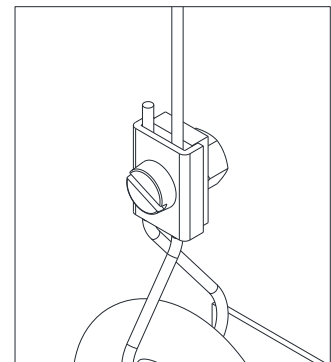
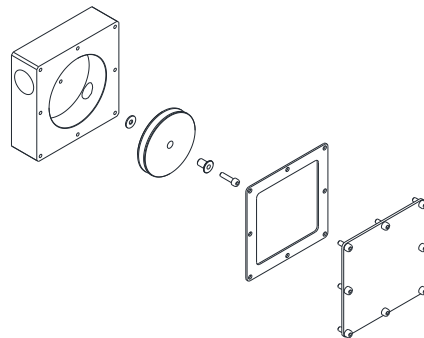
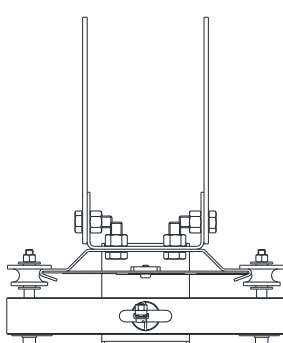

Place the Guide Index (10) in front of the graduated scale making it slide from the top with the graduated' scale guides between the index's rollers, then connect the index (10) to one end of the rope (11) with the clamp (2)
Disassemble the covers of the 90° return idlers (26).



Make the other end of the rope (11) slide through the 90° return idlers (26), ensuring that it lays on the pulleys and lower it to the tank's bottom.

Connect the float (1) to the rope with a wire clamp (2) so that when the float (1) is located at the tank's bottom, the index (10) indicates the "0" on the scale's top.

Check that the instrument operate correctly, then reassemble the covers and gaskets of the 90° return idlers.

2.2 TLQ-41W ASSEMBLING

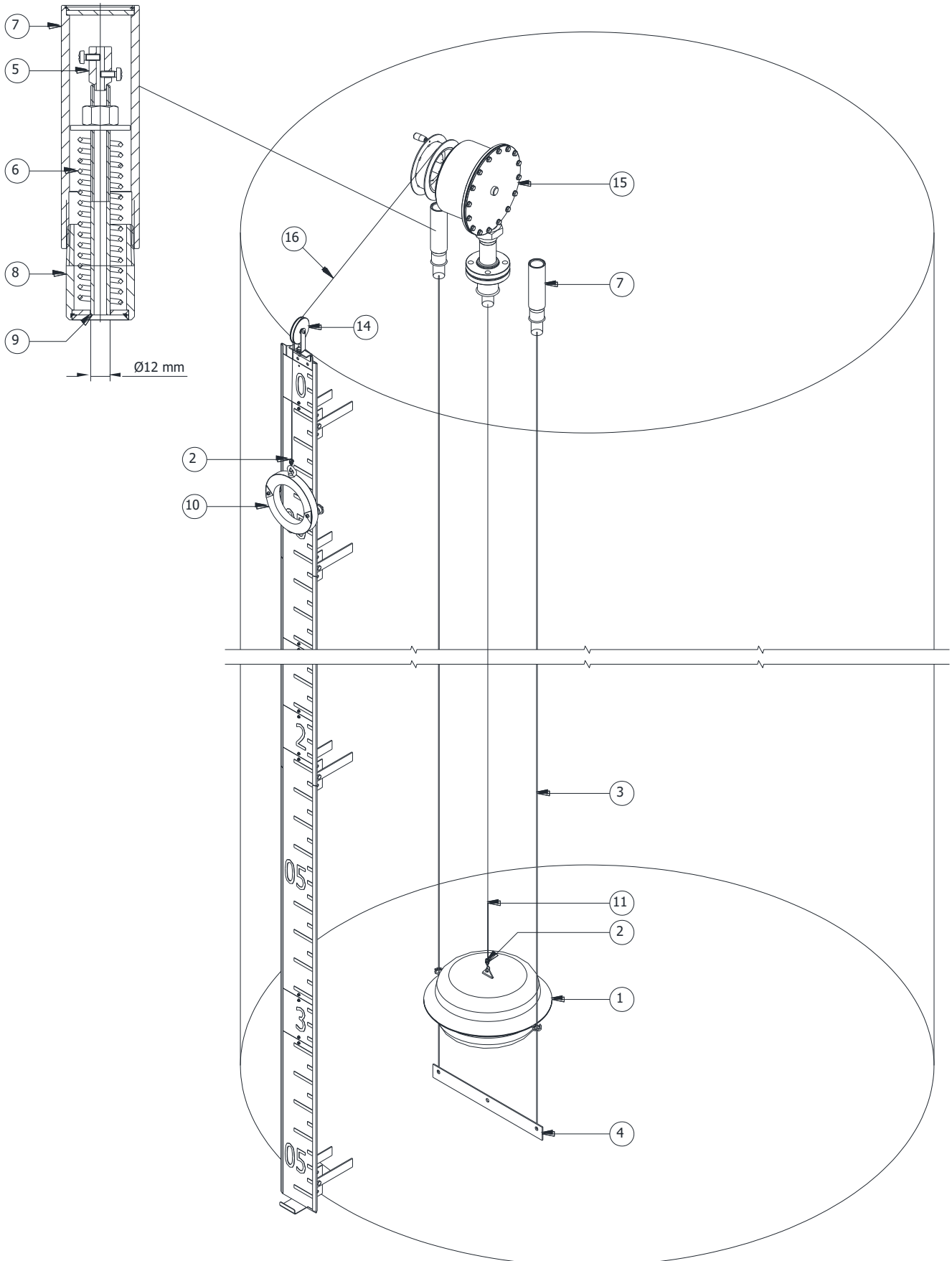

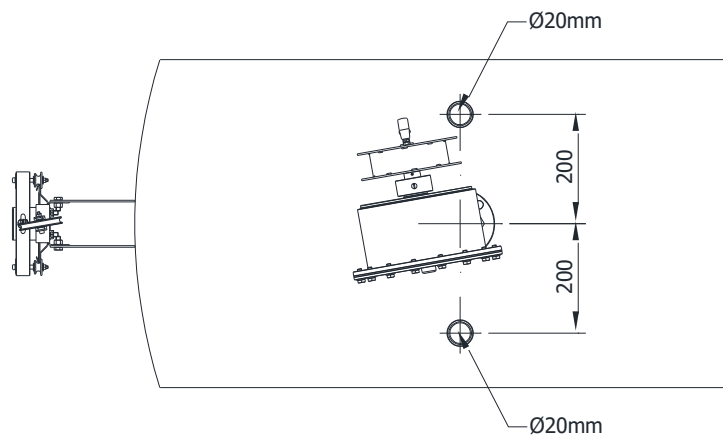
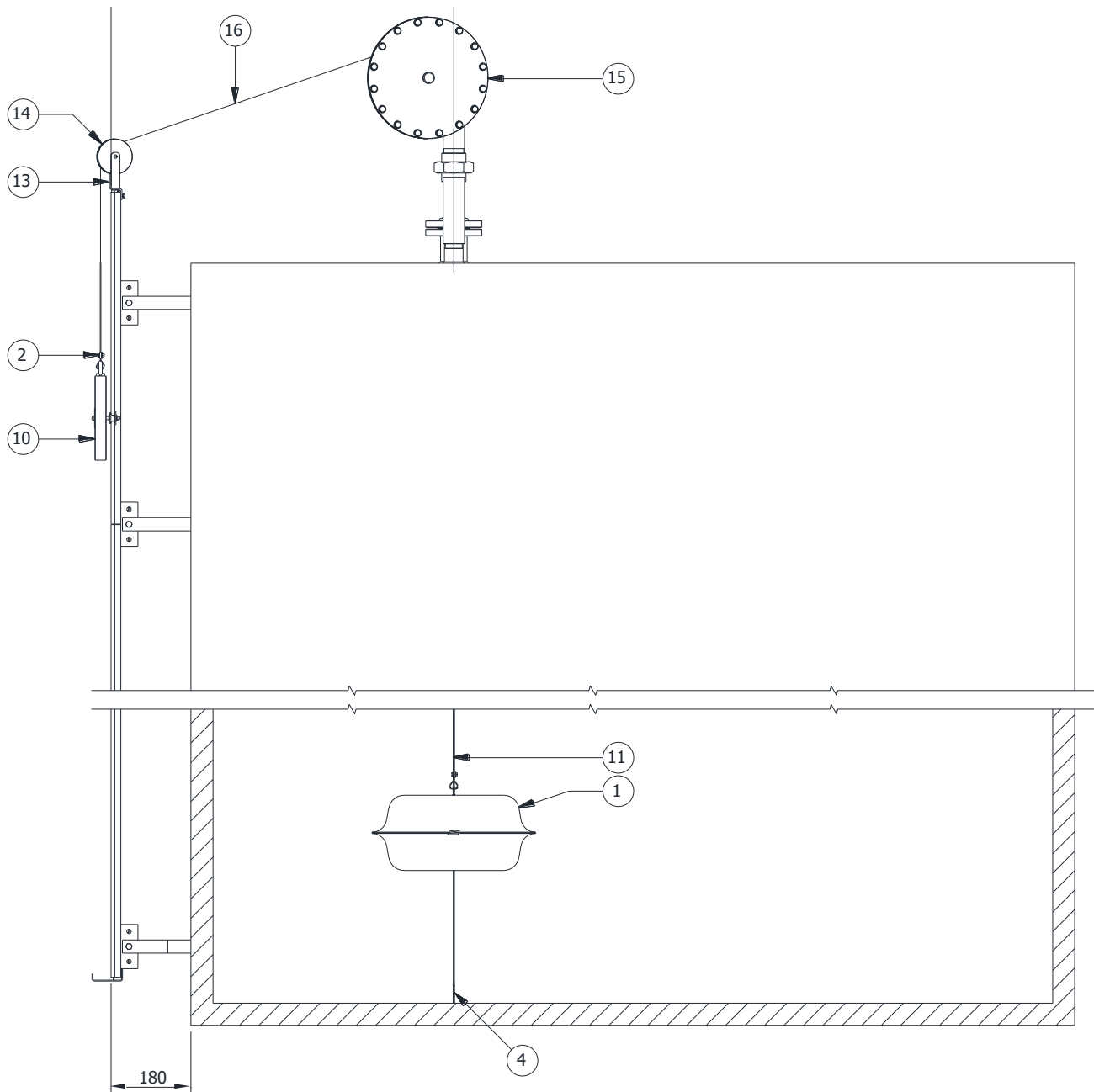



1	Float
2	Wire clamp
3	Guide wire
4	Anchor bar
5	Wire clamp
6	Spring
7	Spring tightening
8	Coupling
9	Wire guide
10	Index
11	Internal wire
13	Scale pulley
14	Pulley
15	Sealed pulley
16	External wire

2.2.1 Anchor bar and spring tightening

Mount the anchor bar (4) and the couplings (8) as written in the paragraph 2.1.1.

2.2.2 Spring tightening and float

Mount the spring tightening (7) and the float (1) as written in the paragraph 2.1.3.

2.2.3 Scale

Mount the scale as written in the paragraph 2.1.4.

In the 41W model the top rail is supplied with the pulley (14) already assembled.

2.2.4 Sealed pulley, index and wire.

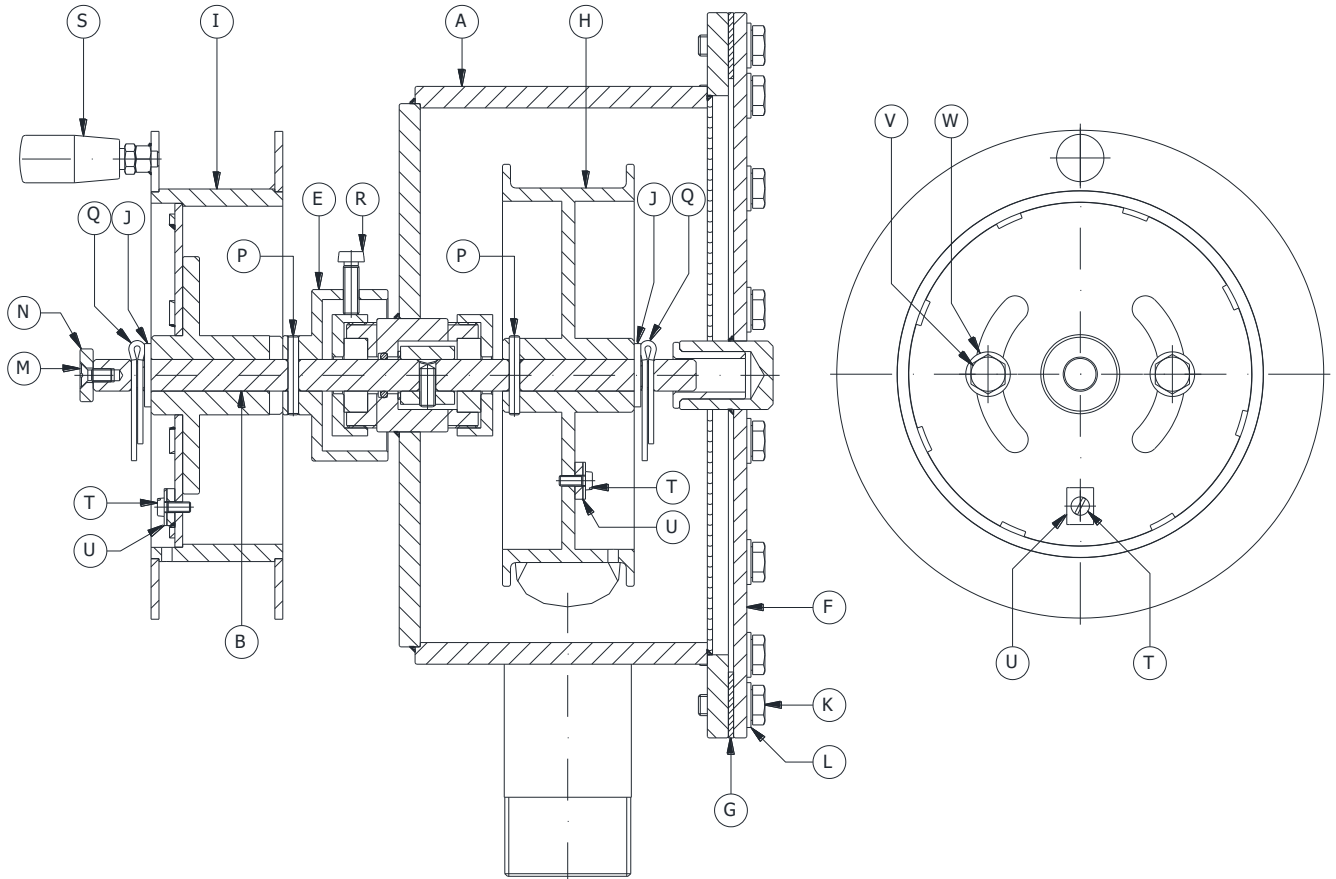

A	Body
B	Axle
E	Joint
F	Cover
G	Seal
H	Internal pulley
I	External pulley
J	Washer
K	Screw
L	Washer
M	Screw
N	Stopper
P	Plug
Q	Cotter
R	Screw
S	Knob
T	Screw
U	Clamp
V	Screw
W	Washer

Place the sealed pulley (15) on the flanged nozzle then, acting on the fitting, orient the sealed pulley so that the external pulley (I) is aligned with the scale's pulley (14) as shown in the top view drawing on the previous pages.

The scale's pulley (14) can be oriented towards the external pulley by unscrewing the nut that connects the pulley (14) to the scale's guide.

Remove the cover (F) and the gasket (G) from the body (A) by removing the screws (K) and washers (L).

Slide the internal wire (11) from inside the sealed pulley (15), through the flanged nozzle, to the tank's bottom and connect it to the float (1) using the wire clamp (2).

Remove the cotter pin (Q) and the washer (J) then detach the internal pulley (H).

Slide the wire (11) through the hole of the pulley (H) near the clamp (U) and connect it to the pulley (H) using the clamp (U) and the screw (T).

Reassemble the pulley (H), the cotter pin (Q) and the washer (J) in the correct position.

Rotate the pulley (H) clockwise, until the cable (11) is completely wrapped on the pulley, then continue rotating it clockwise in order to rise the float (1).

Check that the float (1) slides properly on the guide wire (3).

Rotate the pulley (H) counter-clockwise until the float (1) descends to the tank's bottom.

Tighten the screw (R) in order to block the return axis (B).

Remove the screw (M), the stopper (N), the cotter pin (Q) and the washer (J) then pull the outer pulley (I) and detach it from the axis (B).

Place the index (10) in front of the graduated scale by sliding it from the top with the scale's guides between the index's wheels and connect the index (10) to one end of the external wire (16) with the clamp (2).

Slide the other end of the wire (16) on the scale's pulley (14) and through the hole of the external pulley (I) connect it to the external pulley using the clamp (U) and the screw (T).

Turn the external pulley counterclockwise (I) until the index (10) reaches the "0" on the scale's top, checking that the wire slides correctly on the pulley (14).

It may be needed to further adjust the position of the sealed pulley (15), acting on its fitting, or the position of the scale's pulley (14) acting on the nut under it.

Reassemble the external pulley (I) on the axle (B) by pushing the pulley and finding the correct coupling.

Reassemble the cotter pin (Q), the washer (J), the stopper (N) and the screw (M) and unlock the axle by unscrewing the appropriate screw (R).

If, after reassembling the external pulley, the index (10) has moved from the "0" on the scale, unscrew the external pulley's screws (V) and rotate the pulley until the index (10) returns in the correct position, then re-tighten the two screws (V).

Check that the instrument operate correctly then reassemble the pulley's gasket (G) and cover (F).



2.3 TLQ-39W ASSEMBLY

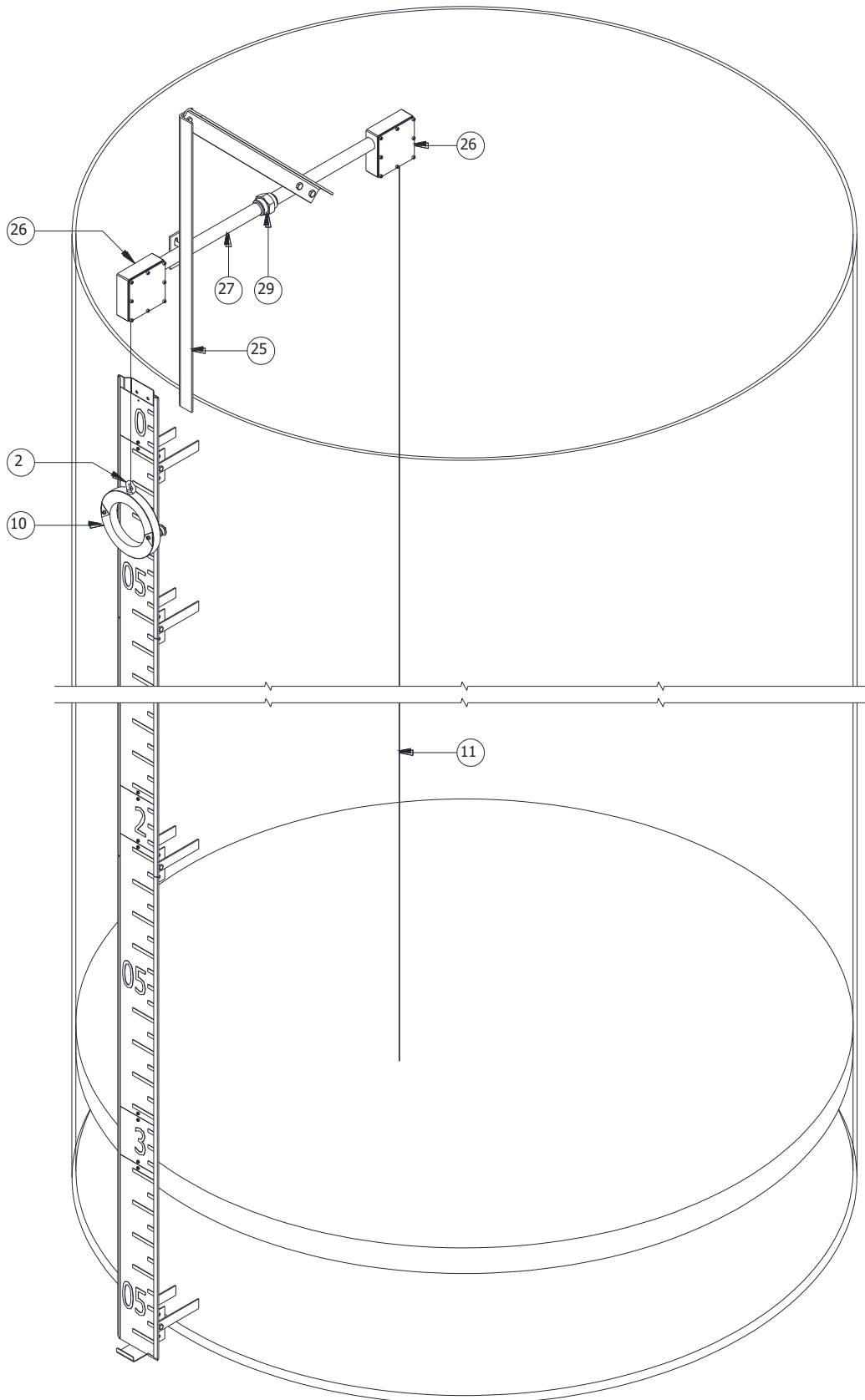

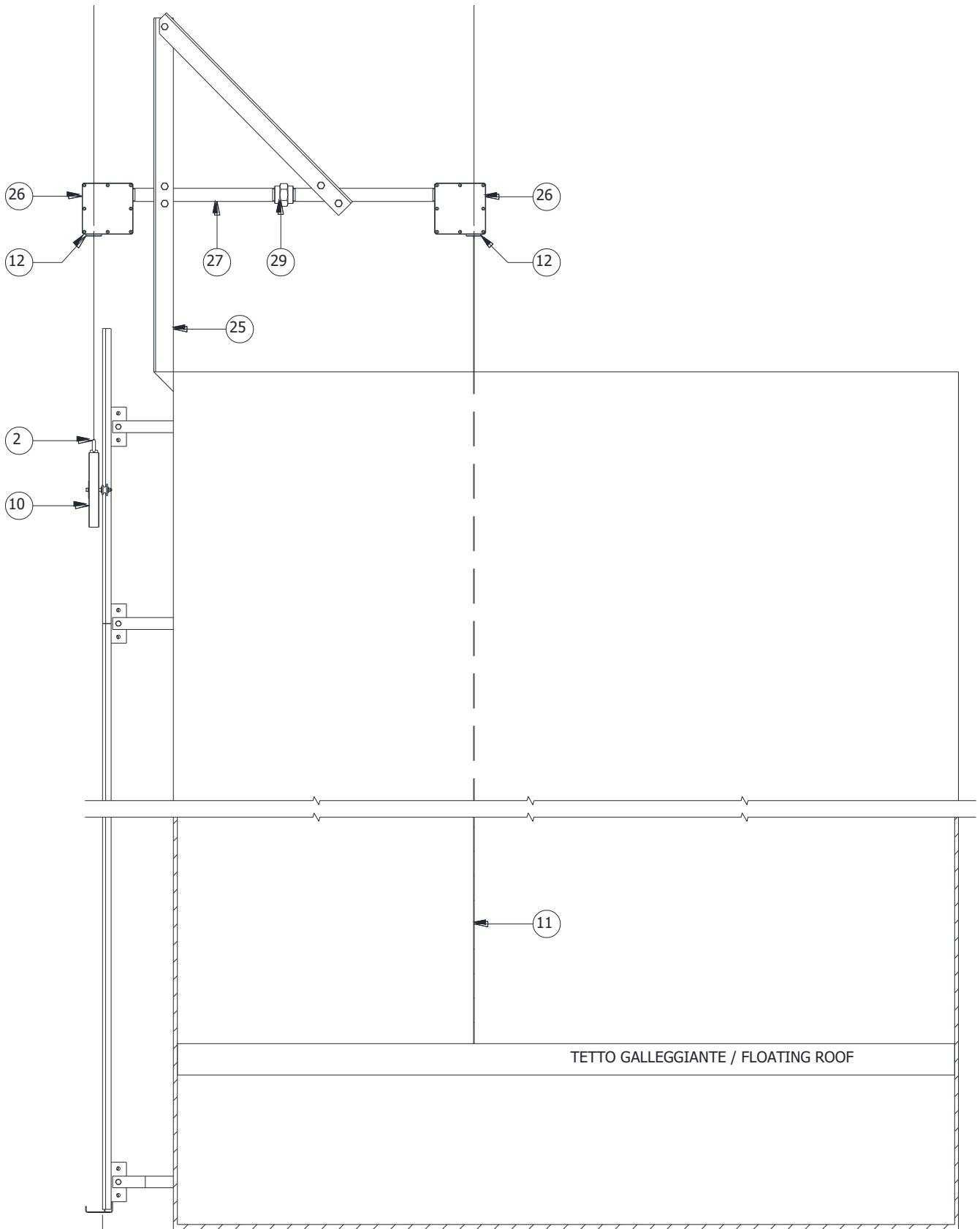

2	Clamp
10	Index
11	Wire
12	Wire guide
25	Bracket
26	90° return idler
27	Connection pipe
29	Fitting

2.3.1 90° return idlers

Weld the Bracket (25) to the tank's roof.

Mount and orient as shown in the previous drawing the 90° return idlers (26) connected by the connections pipes (27) and the fitting (29).

Mount the two connecting pipes (27) on the bracket (25).

2.3.2 Scale

Mount the graduated scale as written in the paragraph 2.1.4.

2.3.3 Index and wire

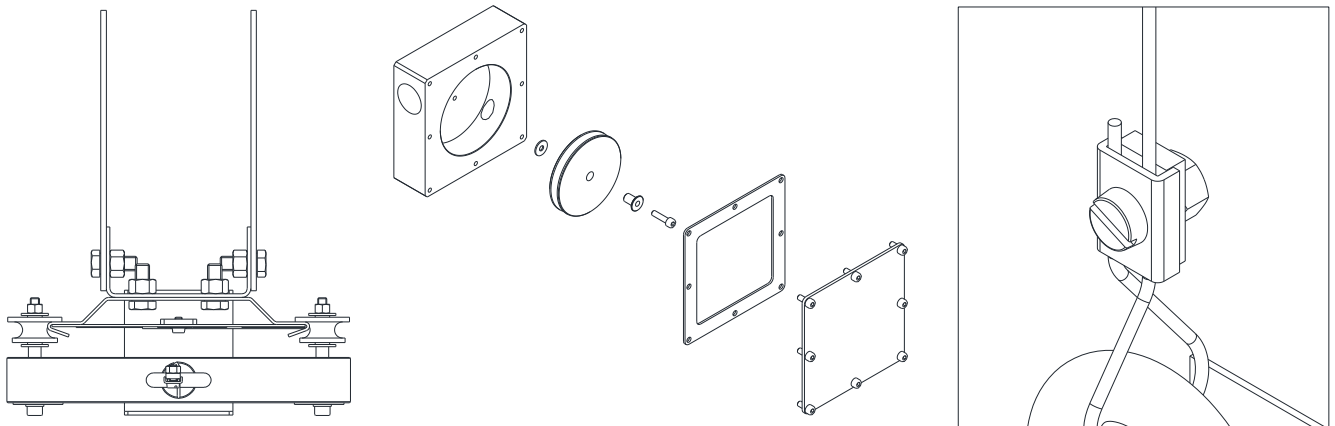

Place the index (10) in front of the graduated scale by sliding it from the top with the scale's guides between the index's wheels and connect the index (10) to one end of the external wire (16) with the clamp (2).

Remove the covers and the gaskets of the 90° return idlers (26).

Slide the wire (26) through the 90° return idlers, checking that it lays on the pulley.

Connect the wire (11) to the tank's floating roof so that when the floating roof lays on the tank's bottom, the index (10) indicates the "0" on the scale's top.

Check that the instrument operates correctly, then reassemble the covers and the seals of the 90° return idlers (26).

2.4 TLQ-40W ASSEMBLY

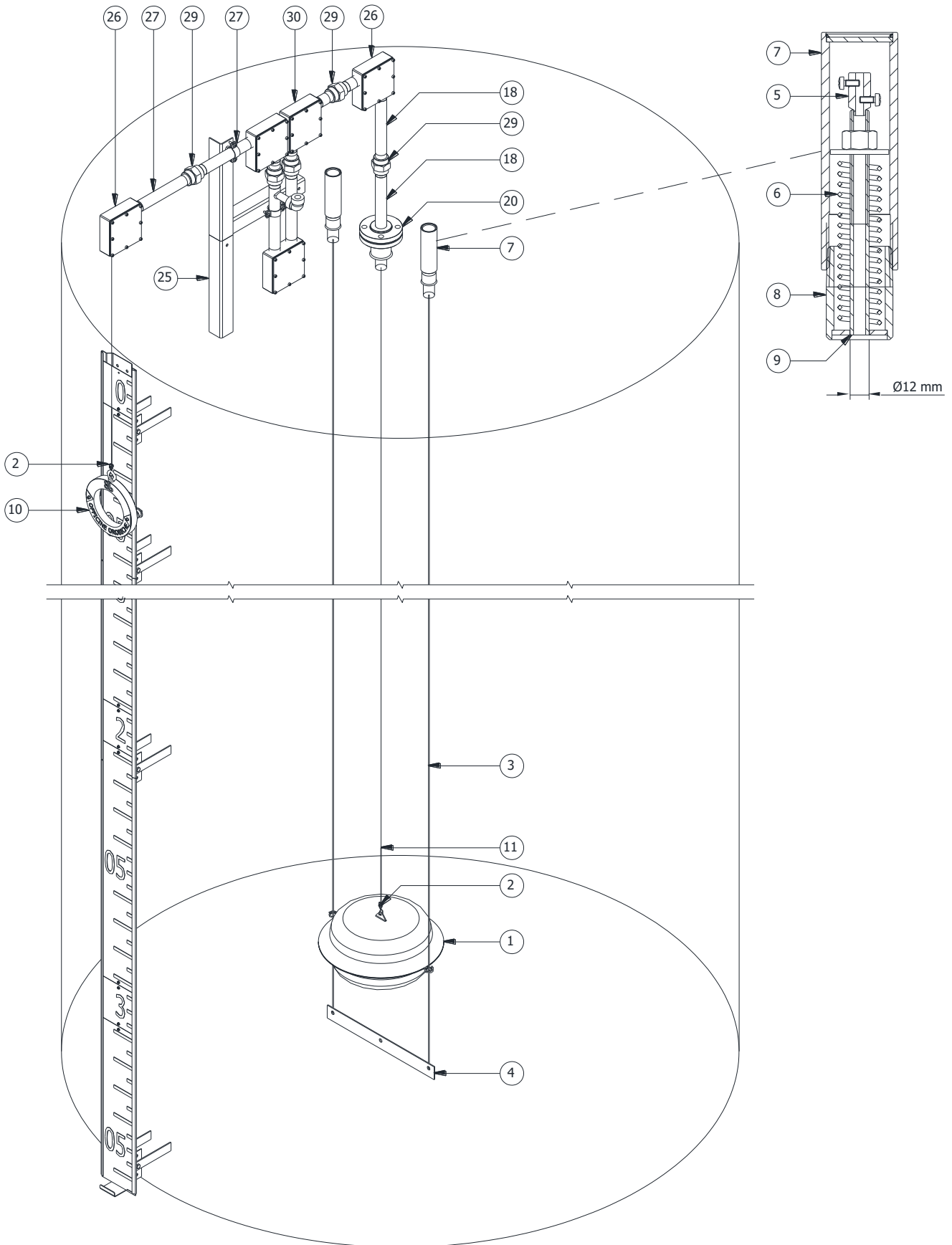

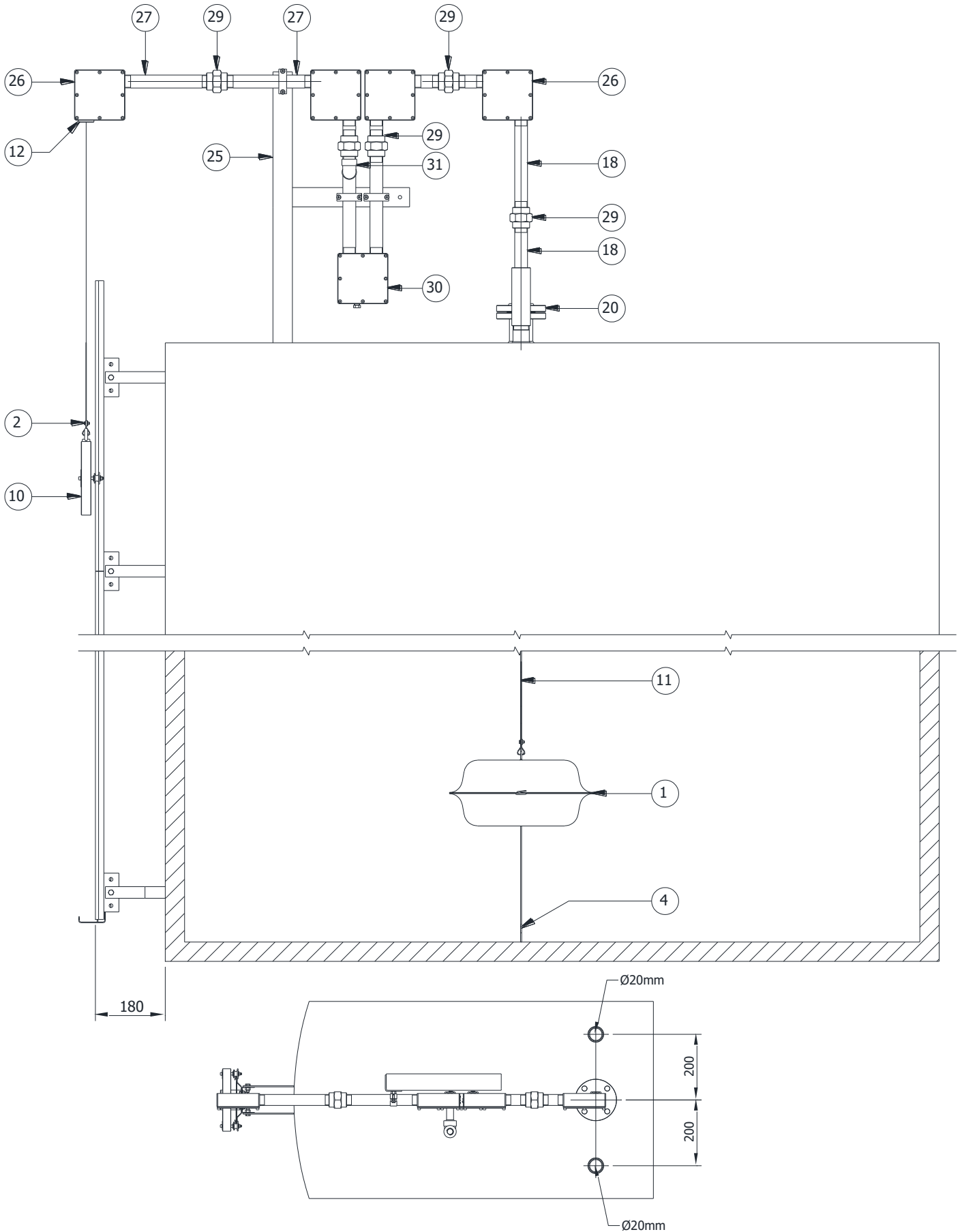



1	Float
2	Clamp
3	Guide wire
4	Anchor bar
5	Clamp
6	Spring
7	Spring tightening
8	Coupling
9	Wire guide
10	Index
11	Wire
12	Wire Guide
18	Connection pipes
20	Flange
25	Pipe bracket
26	90° return idler
27	Connection pipe
29	Fitting
30	Liquid seal
31	Liquid refiller

2.4.1 Anchor bar and spring tightening

Mount the anchor bar and the spring tightenings as written in the paragraph 2.1.1.

2.4.2 90° return idler and liquid seal

Place the flange (20) with the connection pipe (18) on the flanged nozzle.

Assemble and orient as shown in the previous drawing the 90° return idlers (26) and the liquid seal (30), joint together by the connection pipes (27) and by the fittings (29).

Weld the bracket (25) on the tank's roof.

Connect the bracket (25) to the connecting pipes (27) and the liquid seal (30).

2.4.3 Spring tightening and float

Mount the spring tightenings and float as written in the paragraph 2.1.3.

2.4.4 Scale

Mount the scale as written in the paragraph 2.1.4.

2.4.5 Index and wire

Place the index (10) in front of the graduated scale by sliding it from the top with the scale's guides between the index's wheels and connect the index (10) to one end of the external wire (16) with the clamp (2).

Disassemble the covers and the gaskets of the 90° return idlers (26) and of the liquid seal (30).

Slide the other end of the wire (11) through 90° return idlers (26), and through the liquid seal (30) checking that it correctly lays on the pulleys and drop it to the tank's bottom.

Connect the float (1) to the wire (11) with the clamp (2) checking that when the float (1) lays on the tank's bottom, the index (10) indicates the "0" on the scale's top.

Check that the instrument operates correctly, then reassemble the covers and the gaskets of the 90° return idlers and of the liquid seal (30).

Fill the liquid seal (30) with oil using the liquid refiller (31).

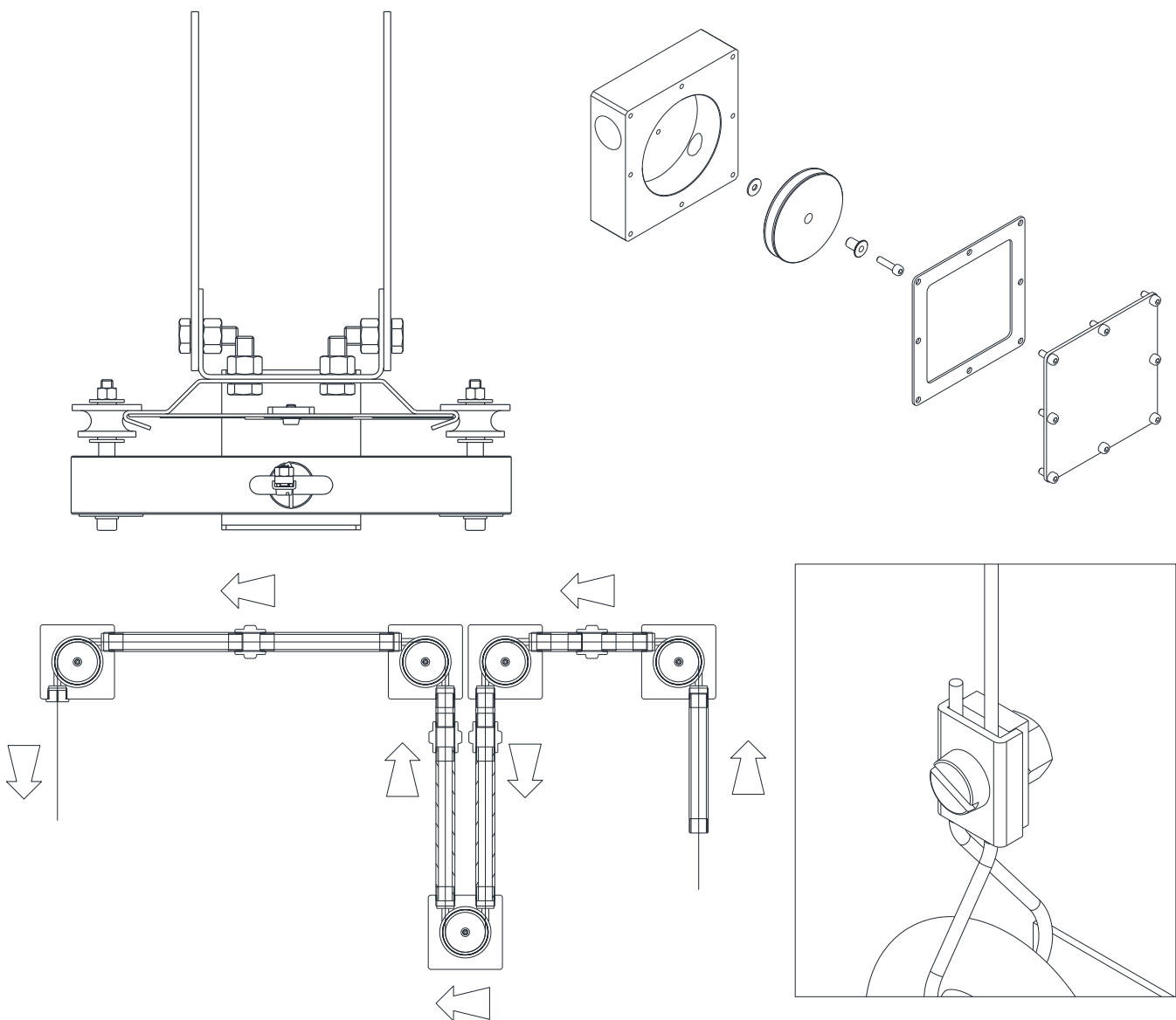

2.5 TLQ-37W ASSEMBLY

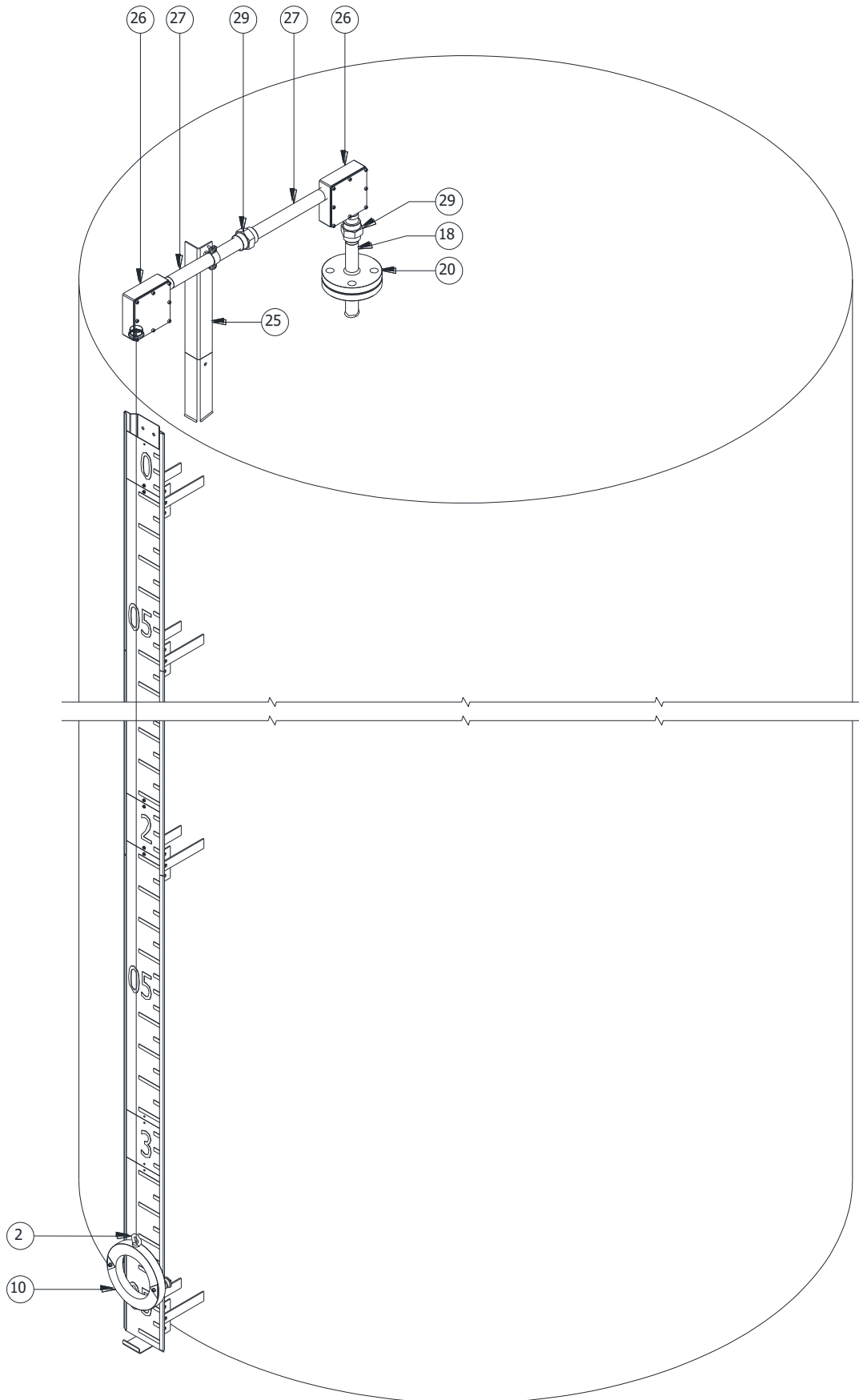

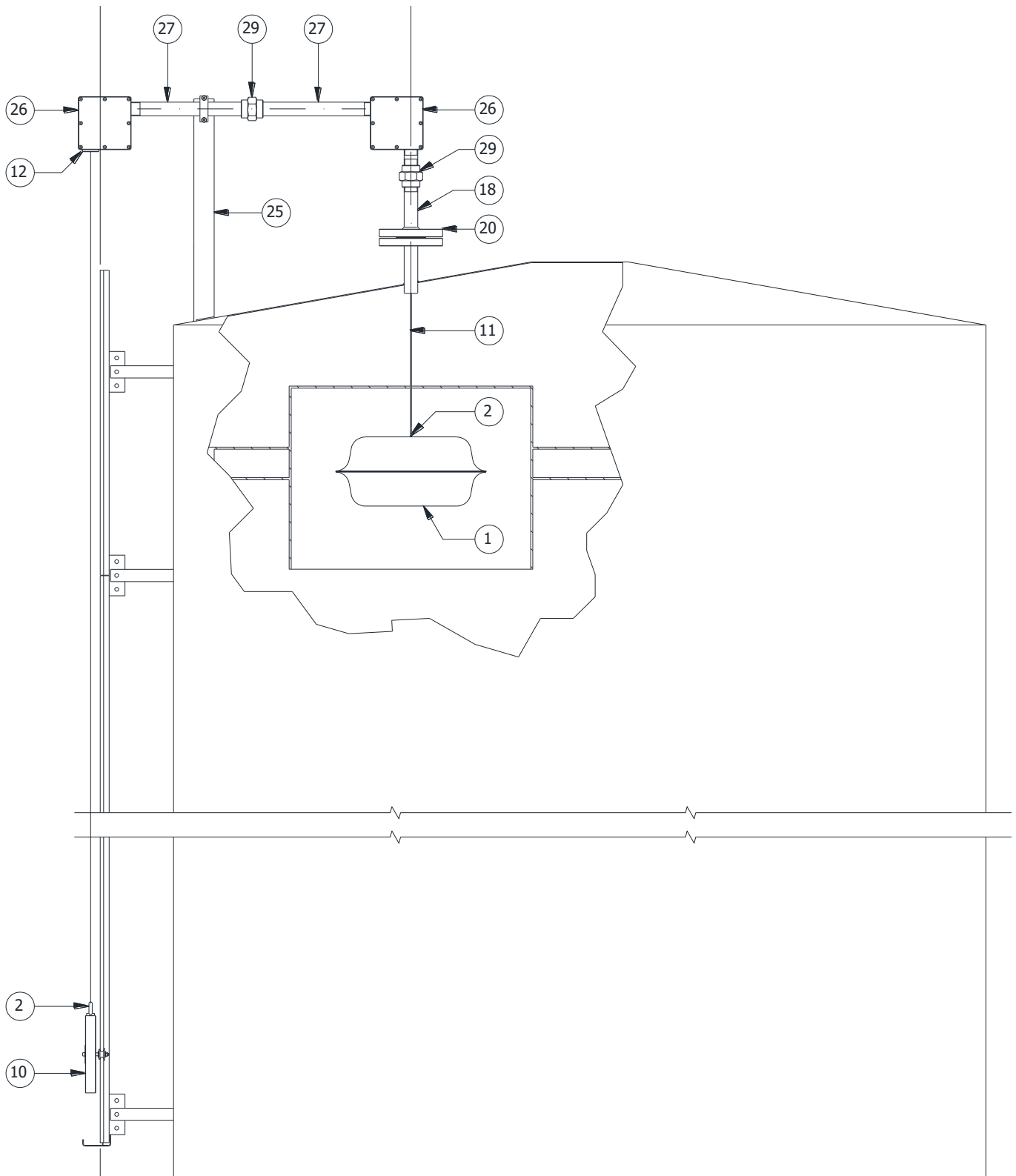



1	Float
2	Clamp
10	Index
11	Wire
12	Wire Guide
18	Connection pipe
20	Flange
25	Pipe bracket
26	90° return idler
27	Connection pipe
29	Fitting

2.5.1 90° return idlers

Mount the 90° return idler as written in the chapter 2.1.2.

2.5.2 Float

Place the float (1) in the dedicated place on the tank's floating roof.

2.5.3 Scale

Mount the scale as written in the chapter 2.1.4.

2.5.4 Index e wire

Mount the index (10) and the rope (11) as written in the chapter 2.1.5, considering that in this model the float lays on the floating roof.

3 T25 SERIES LEVEL SWITCH

Level indicators TLQ-xxW Series can be equipped with one or more reed contacts T25 Series. For this execution the index is supplied with a magnet in order to act on the contact.

The switching point can be regulated by moving the switch along a support.

For more information check the T25 Series documentation.

3.1 ASSEMBLY

1	Bracket support
2	T25 Series
3	Bracket
4	Bracket
5	Screw
6	Nut
7	Nut
8	Screw
9	Nut
10	Screw
11	Index

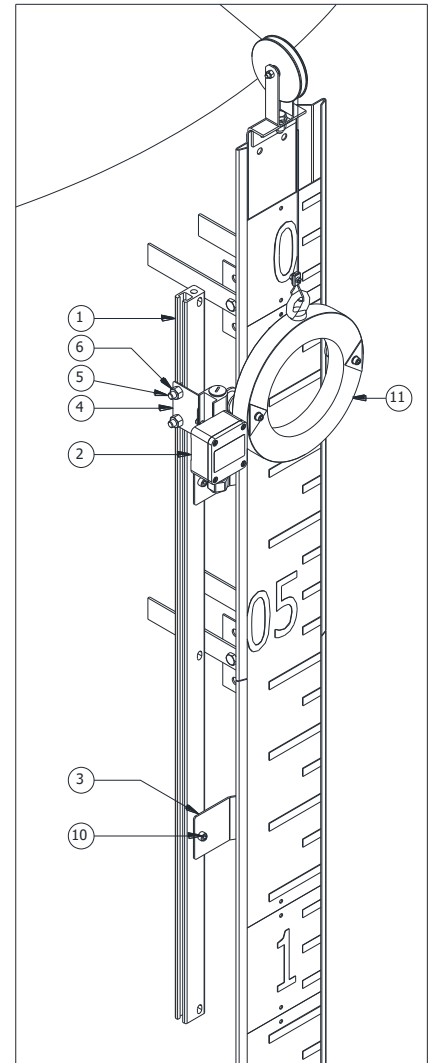
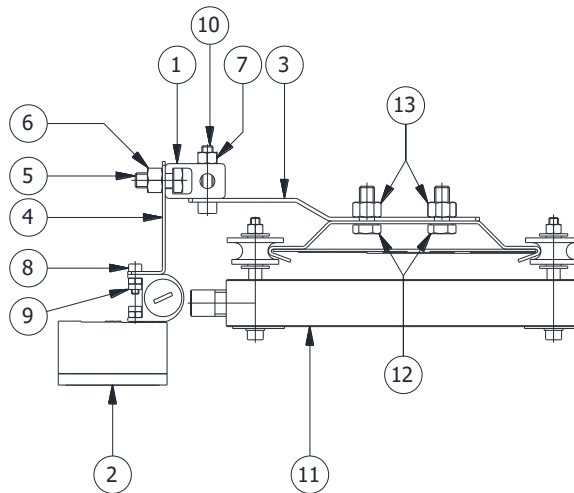

Mount the two brackets (3) on the scale's guide by passing two screws (12) through the bracket and trough the two holes on the back of the scale's guide.

Mount the bracket support (1) to the two brackets (3) using one screw (10) for each bracket (3).

Mount the T25 Series switch (2) to the bracket (4) using the screw (8) and the nut (9).

Mount the switch (2) and its bracket (4) on the bracket support (1), using the screw (5) and the nut (6).

The switching point can be regulated by moving the switch's bracket along the support (1).

4 MAINTENANCE

Check frequently that the wires and the index slide correctly and that all the pulleys are clean and without the presence of external materials.