

ULS SERIES - ULTRASONIC LEVEL SWITCH

DESCRIPTION

The level switch is designed for checking of the liquids level in industrial and marine applications, pumps control, for detection of levels in overflow pipes, high and low alarm level on liquids with or without foam.

The level switch works on the principle of distributed acoustic waves in a metal rod. If the rod is not covered by the liquid the sound waves are dispersed freely without any interference.

When the liquid covers the rod the emission of sound wave is muffled and this interference is picked up by the piezoelectric sensor and transmitted by a signal to the current loop.

These instruments have no moving parts, no vibration, no optical or capacitive detectors. They are pure static sensor offering the maximum reliability.

INDUSTRIAL APPLICATIONS

- Min / max level alarms for water and returned waters, light muds, viscous fluids, food fluids, oils, chemical products, acids, caustic soda, pharmaceutical products, petrolchemical products, etc.

MARINE APPLICATIONS

- Detection of water presence
- Detection of levels in overflow pipes
- High and low alarm system in tanks, wells, separators, etc.
- System in accordance with IMO rules and Coast Guard for "high" and "high-high" alarm.

TECHNICAL FEATURES

- If the liquid wets the probe for at least 10mm it becomes active; differential of 5 mm. for vertical mounting and of 3 mm. for horizontal mounting
- All parts in contact with the fluid are in AISI 316
- It does not require any calibration
- Aluminium housing, painted with epoxy cicle, water proof or explosion proof ATEX
- Alarm output 2 wires or relay mounted on field or back-of-board on guide DIN
- Different power supplies available.
- Isolation > 5Ghom at 500V a.c.
- Operating temperature: -40 +90° C
- Stocking temperature: -40 +90° C
- Length of the probe: from 25 to 600 mm. (std. 114 mm.) other lengths on request
- Operating pressure 100 Bar, or according to the type of process connection

APPROVAL

- CE: Direction EMC 89/336
- EN50082 - 2, EN61000 - 4 - 2, EN50141, EN61000 - 4 - 4, ENV50140
- EN50081 - 2, EN55011
- EP: ATEX II 1/2 G Ex d IIC T6 o T5 Ga/Gb
ATEX II 1/2 D Ex ta/tb IIIC T85° o T100° C Da/Db
CESI certificate n. 02-ATEX-126
- WP: IP66

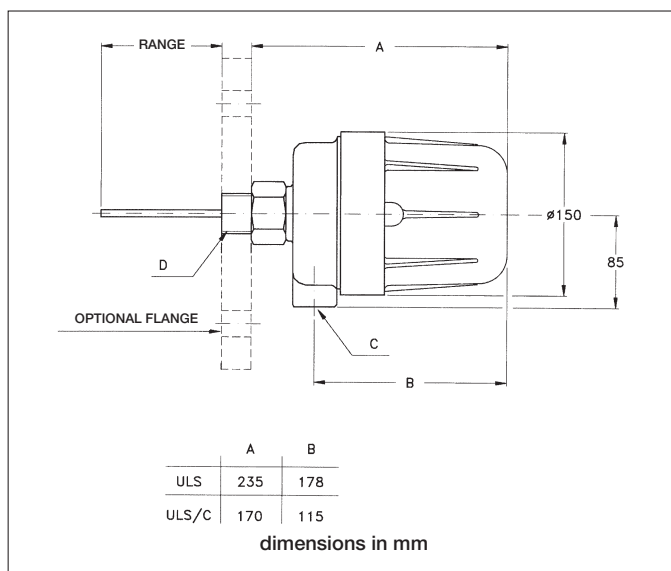

STANDARD CONNECTIONS

- D) Process connection: 3/4" GAS - M; 3/4" NPT-M
- C) Electrical connection: UNI 6125; NPT-F and ISO m20X1.5 (on request)

Eventual option for flange in carbon steel or inox, from 1" up to 6" ANSI 150 - 600 or UNI / DIN

WEIGHT:

- Threaded version 5 kg

MOUNTING

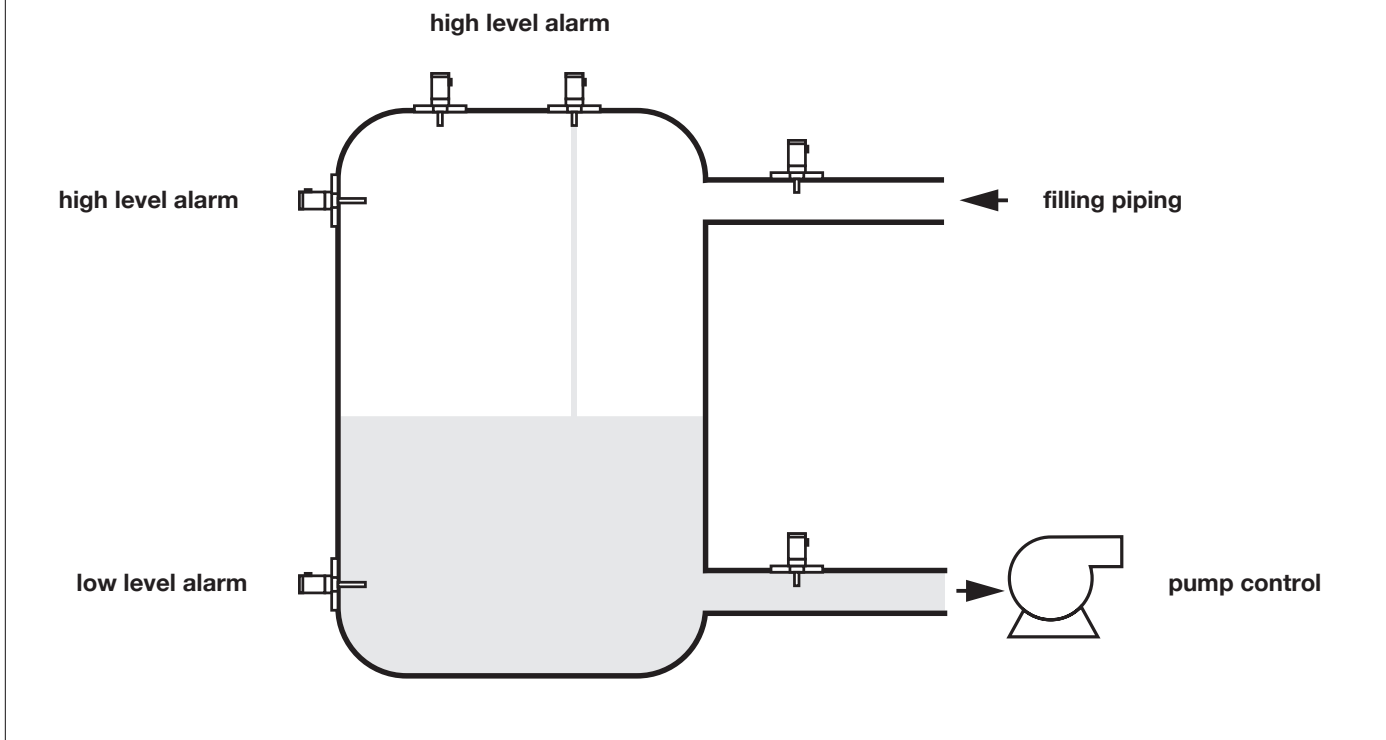

MODEL

ULS = version with standard housing (A = 235 mm)
 ULC = version with "short" housing (A = 170 mm)

PROCESS CONNECTION

G = 3/4" GAS - M
 N = 3/4" NPT - M
 F = Flange ANSI/UNI/DIN

RANGE

0114 = STD measure 114 mm
 xxxx = request measure in mm

MATERIAL OF THE PROBE

J = AISI 316

HOUSING

WP = Water proof IP66
 EP = explosion proof ATEX

HOW TO ORDER

Example: ULS - 0114 - G - J - AC - EP

ULS model
 0114 range in mm
 G process connection 3/4 GAS - M
 J material of the probe AISI 316
 AC circuit
 EP housing Ex-d

CIRCUIT

- AC= Relay 8A 250V a.c. DPDT hermetically sealed, power supply 24V d.c. - a.c.
- AE= Relay 8A 250V a.c. DPDT hermetically sealed, for back-of-board mounting on guide DIN, power supply 24V d.c. - a.c.
- BC= Relay 8A 250V a.c., hermetically sealed, power supply 110/220V a.c.
- BE= Relay 8A 250V DPDT hermetically sealed, for back-of-board mounting on guide DIN, power supply 110/220V a.c.
- EA= Output (2 wires) 5/13 mA, power supply 15-30V d.c.; ATEX EEia IIC T6 certificate