

FLS SERIES FLOAT LEVEL SWITCH

The FLS level switch is reliable solution to check and/or settle the level of the liquid in the drain water's heaving stations, in the sewer water pumping station or industrial wassing, industrial waste, fuel diesel or hydrocarbon tanks, oil tanks, etc.

The switch doesn't require any maintenance because there are no moving parts. The switch is contained in a polyethylene casing which hangs free on a cable at the needed height.

It goes with the level variations of the liquid, therefore it closes or opens a contact by changing position (vertical/horizontal), in this way it sets going a signal or a pump.

A counterweight is eccentrically mounted, in order to hold the level regulator in the right position.

FSL level switch assures a good resistance at the main part of the chemical agents.

The float switch is filled with closed cells non hygroscopic expanded polyurethane, eliminating all air, sealing the unit and completely surrounding the electric control switch.

The FSL Series level switch is available in two versions:

- **Standard, with body of red colour and black cable in PVC-FROR, Mod. FLS-S**
- **ATEX approved, with body and special cable of blue color, Mod. FLS-A**

- Differential ~ 30°.
- The electrical cable is fixed inside the tank or by employing the proper hooks and redances.
- Power supply cable not replaceable, in case of damage the entire device must be replaced.
- The height of the switch determined the set point.
- For starting and stop of each pump, n°2 FLS level switches should be employed.
- A version approved for drinking water is available on request.

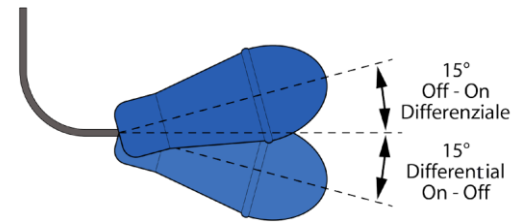

Mod. FLS-S

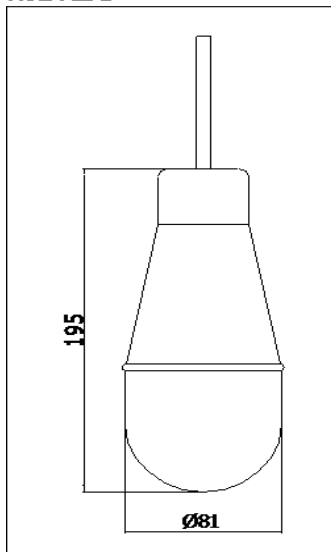

Mod. FLS-A

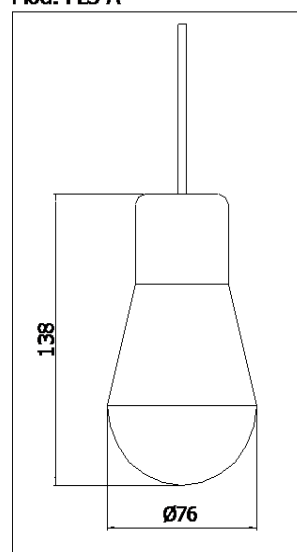

TECHNICAL CHARACTERISTICS	MODEL FLS-S	MODEL FLS-A (ATEX Certified no. 553233X)
Density of the liquid	$\geq 1 \text{ Kg/dm}^3$	$\geq 0,80 \text{ Kg/dm}^3$
Operating temperature	$0 \div +55 \text{ }^\circ\text{C}$	$-20 \div +40 \text{ }^\circ\text{C}$
Immersion depth	20 m	20 m
Operating pressure	10 bar	10 bar
Contact	no.1 SPDT	No. 1 SPDT
Contact rating	250 V AC 10° / 24 V DC 1A	13V DC 21,4 mA / (250V AC 10A **)
Mechanical protection degree	IP 68	IP 68
Electric protection degree	/	II 1G Ex ia IIC T6
Cable length	5; 10; 20 m	5; 10; 20 m

** If installed in a safe area without an intrinsically safe barrier.

WIRING DIAGRAM

To conform to local regulations, the level regulators are normally connected through a transformer to a low tension control circuit.

Two regulators are used, one for starting and one for stopping.

Outline A)

Electrical connection diagram for filling pump.

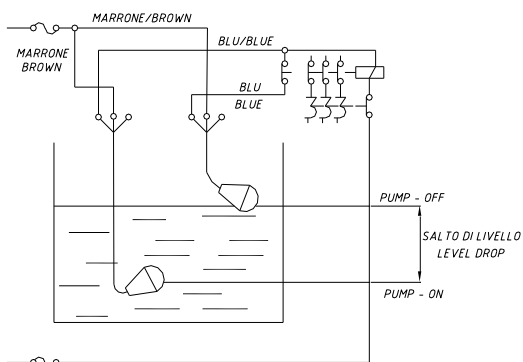

Outline B)

Electrical connection diagram for emptying pump.

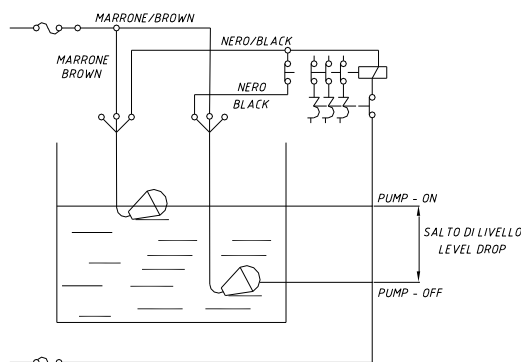

Model FLS-S

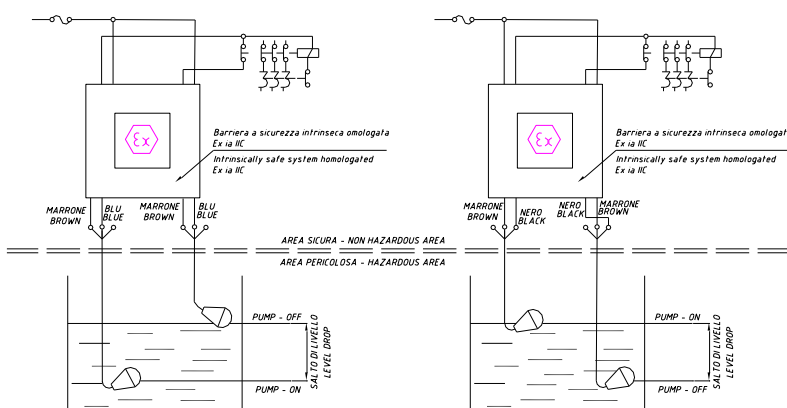

Model FSL-A

HOW TO ORDER:

- FLS-S.5 : Standard level switch with 5 m of cable.
- FLS-S.10: Standard level switch with 10 m of cable.
- FLS-S.20: Standard level switch with 20 m of cable.
- FLS-A.5 : ATEX-EX level switch with 5 m of cable.
- FLS-A.10: ATEX-EX level switch with 10 m of cable.
- FLS-A.20: ATEX-EX level switch with 20 m of cable.

