

VISUAL FLOW INDICATORS - IVF SERIES

SPO MODEL

Visual flow indicator with moveable paddle for horizontal mounting. For pressure up max. 10 Bar and temperature from -196 °C up to max. +130 °C for standard metallic version. On request, versions for higher pressures and temperatures can be made up to 450 °C.

The version in plastic is available in models up to SPO 80. This instrument can be used as a flowmeter since it has a graduated scale on each of the glasses showing the flow rate with calibration for water.

The accuracy of flow indication is $\pm 15\%$ of F.S.

Flow indicators are devices for the visual confirmation that a fluid is flowing through the pipelines.

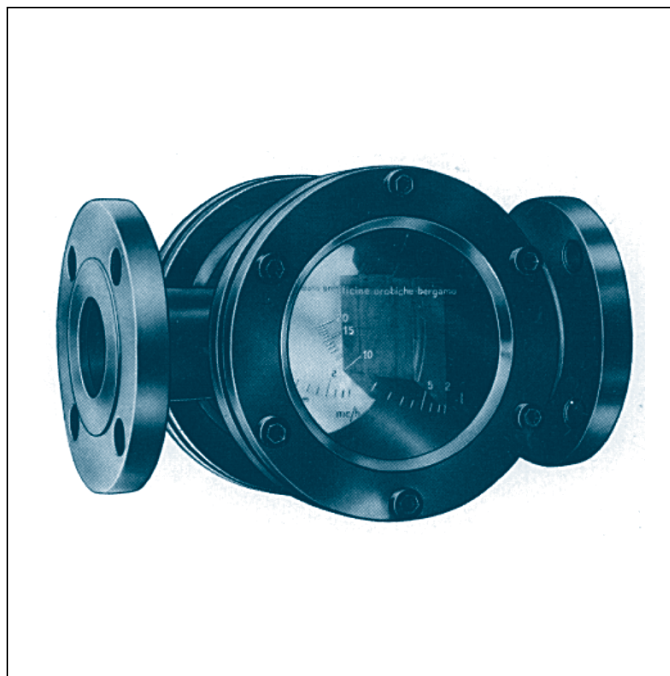

FLANGED

Standard "C" flange UNI PN 10 - ANSI 150 RF.
On request, other types of flanges can be made.

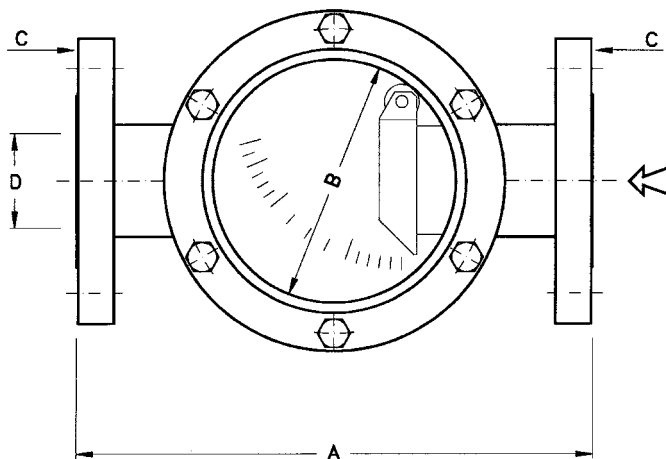

MOD.	A mm	B mm	D		Q max mc/h		WEIGHT ⁽²⁾ ~ kg
			UNI	ANSI	Metallic	Plastic ⁽¹⁾	
SPO 15	170	47	15	1/2"	1,2	1	3
SPO 20	180	60	20	3/4"	3	1	3,8
SPO 25	180	60	25	1"	3	2,5	4,5
SPO 32	230	75	32	1 1/4"	6	5	6
SPO 40	260	90	40	1 1/2"	10	6	8,5
SPO 50	280	120	50	2"	20	25	13
SPO 65	300	120	65	2 1/2"	30	25	17,5
SPO 80	330	145	80	3"	50	40	25
SPO 100	380	170	100	4"	100	-	32

1) See table for "Tolerance limits of plastic type visual indicators". 2) Refers to metallic type.

THREADED

Standard "C" threaded connections
GAS/NPT-F and socket welding.

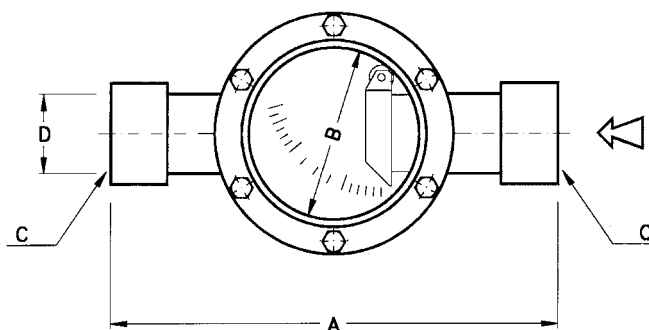

MOD.	A mm	B mm	D	Q max mc/h		WEIGHT ⁽²⁾ ~ kg
				Metallic	Plastic ⁽¹⁾	
SPO 15	200	47	1/2"	1,2	1	1,5
SPO 20	210	60	3/4"	3	1	2
SPO 25	220	60	1"	3	2,5	2,5
SPO 32	280	75	1 1/4"	6	5	4
SPO 40	320	90	1 1/2"	10	6	6
SPO 50	340	120	2"	20	25	9
SPO 65	370	120	2 1/2"	30	25	12
SPO 80	400	145	3"	50	40	19

1) See table for "Tolerance limits of plastic type visual indicators". 2) Refers to metallic type.

MATERIALS

CODE FOR:	Materials	Carbon steel	AISI 304	AISI 316	PVC	Moplen
	Body	A (1)	I (1)	J (1)	P (2)	M (2)
	Paddle	-	-	2	5	6

(1) Internal gaskets Asbestos free (A) Neoprene (N) Teflon (T) Viton (V) - (2) Internal gaskets Neoprene (N) Viton (V)

The flanges of the glasses and the screws can be supplied in galvanized steel or AISI 304.

TOLERANCE LIMITS OF THE PLASTIC TYPE VISUAL INDICATORS

MATERIALS	PVC	MOPLEN
	from 0° C to + 60° C pressure 6 bar a 25° C; 4 bar at 35° C; 1 bar at 60° C	from 0° C a + 80° C pressure 6 bar at 25° C; 4 bar at 45° C; 1 bar at 80° C

HOW TO ORDER

Example: IVF/SPO 50 - A - 2 - N

IVF/SPO IVFseries, SPO model

50 diameter of connections

A body in carbon steel

2 paddle in S/steel AISI 316

N Neoprene gaskets

The following data is also required: type of fluid, specific weight, operating temperature and pressure.